

Abstract

Wingtip devices can decrease tip vortex strength, and thereby improve the performance of aircrafts, marine vehicles and turbines. The goal of the project is to design wingtip devices for marine applications and evaluate their lift, drag, and cavitation characteristics. The performance of different baseline wingtip devices was characterized using the open source computational fluid dynamics (CFD) software OpenFOAM. The results were validated through experimental testing in the UNH high speed cavitation tunnel (HiCaT).

Numerical – Comparison of various wingtip devices using state-of-the-art software for computational fluid dynamics OpenFOAM

End Cap

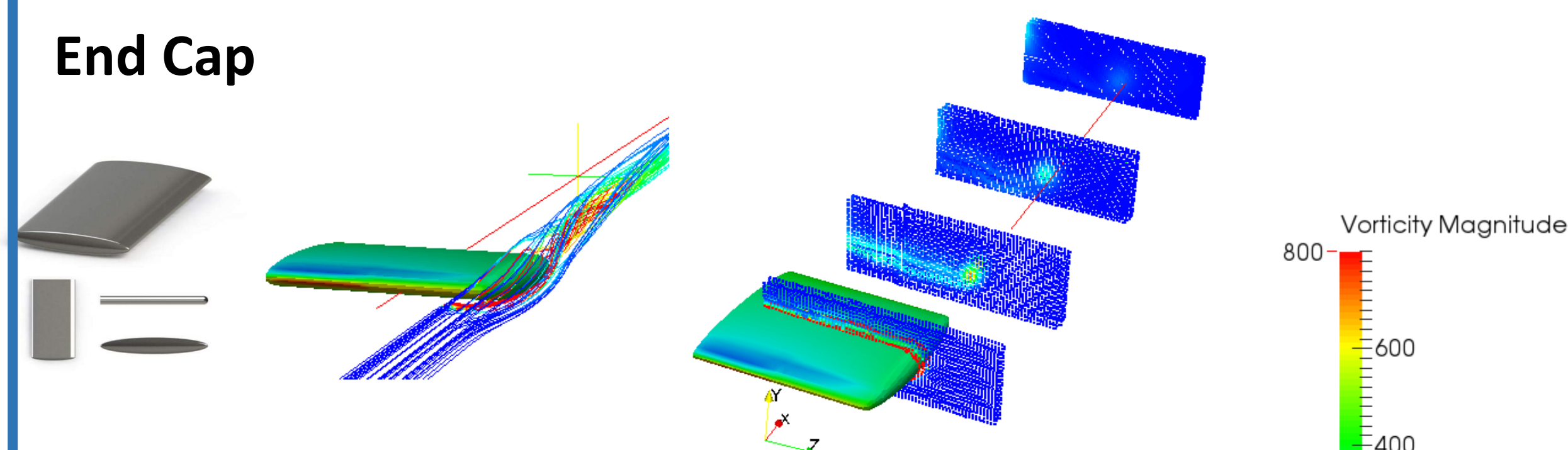

General Foil

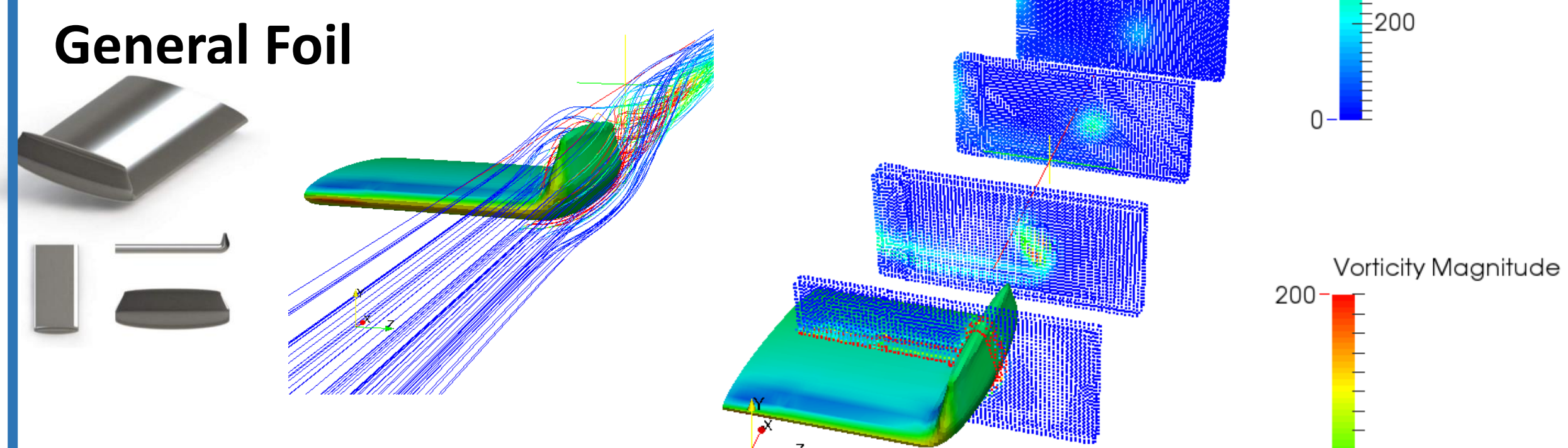

Split Tip

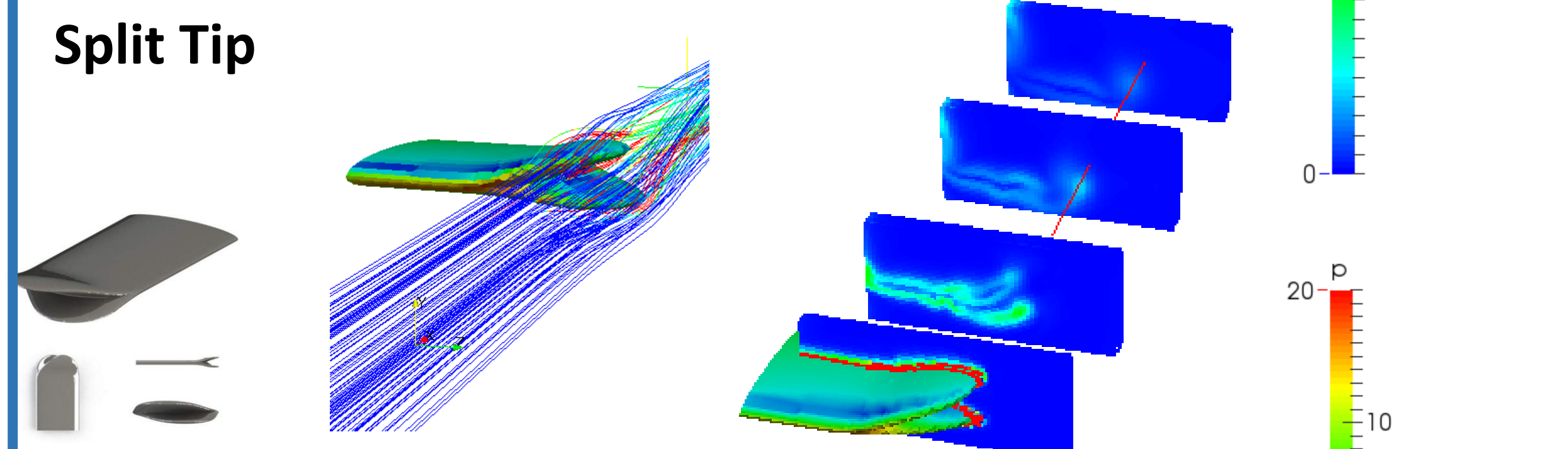

Twist Tip

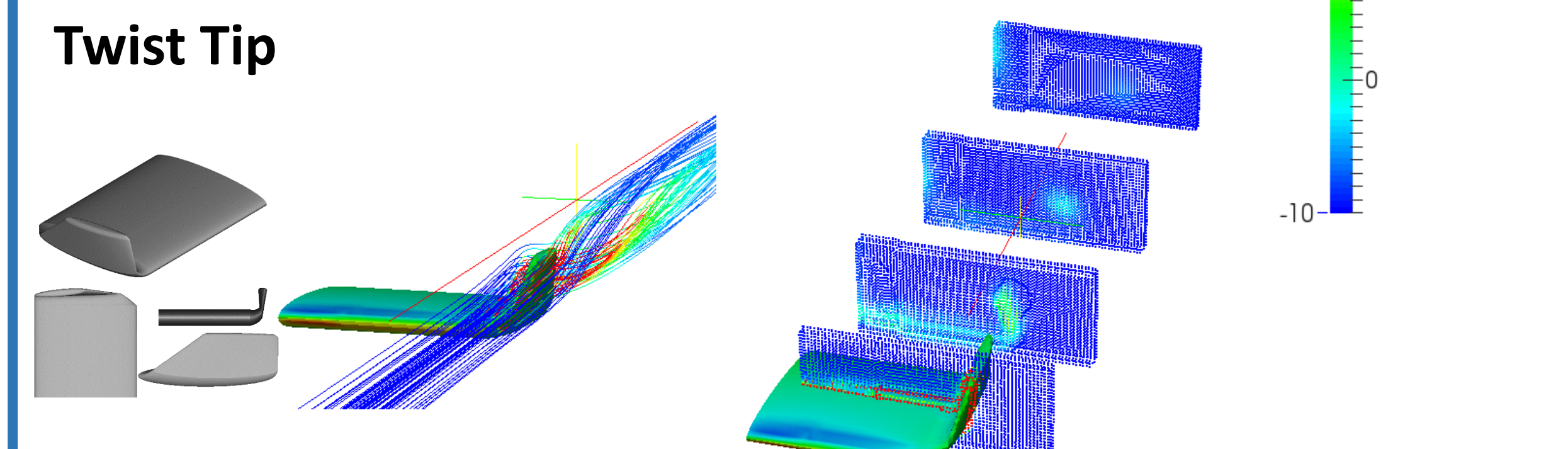

Theoretical – Investigation of existing information about wingtip devices, marine turbines, propellers etc.

Design Requirements for Wingtip Devices

- Improve performance of hydrofoils
- Control cavitation
- Decrease size of wingtip vortices
- Avoid bio-fouling

Cavitation

- Formation of vapor in a liquid in regions of low pressure.
- Detrimental to the performance of devices
- May cause damage and destruction

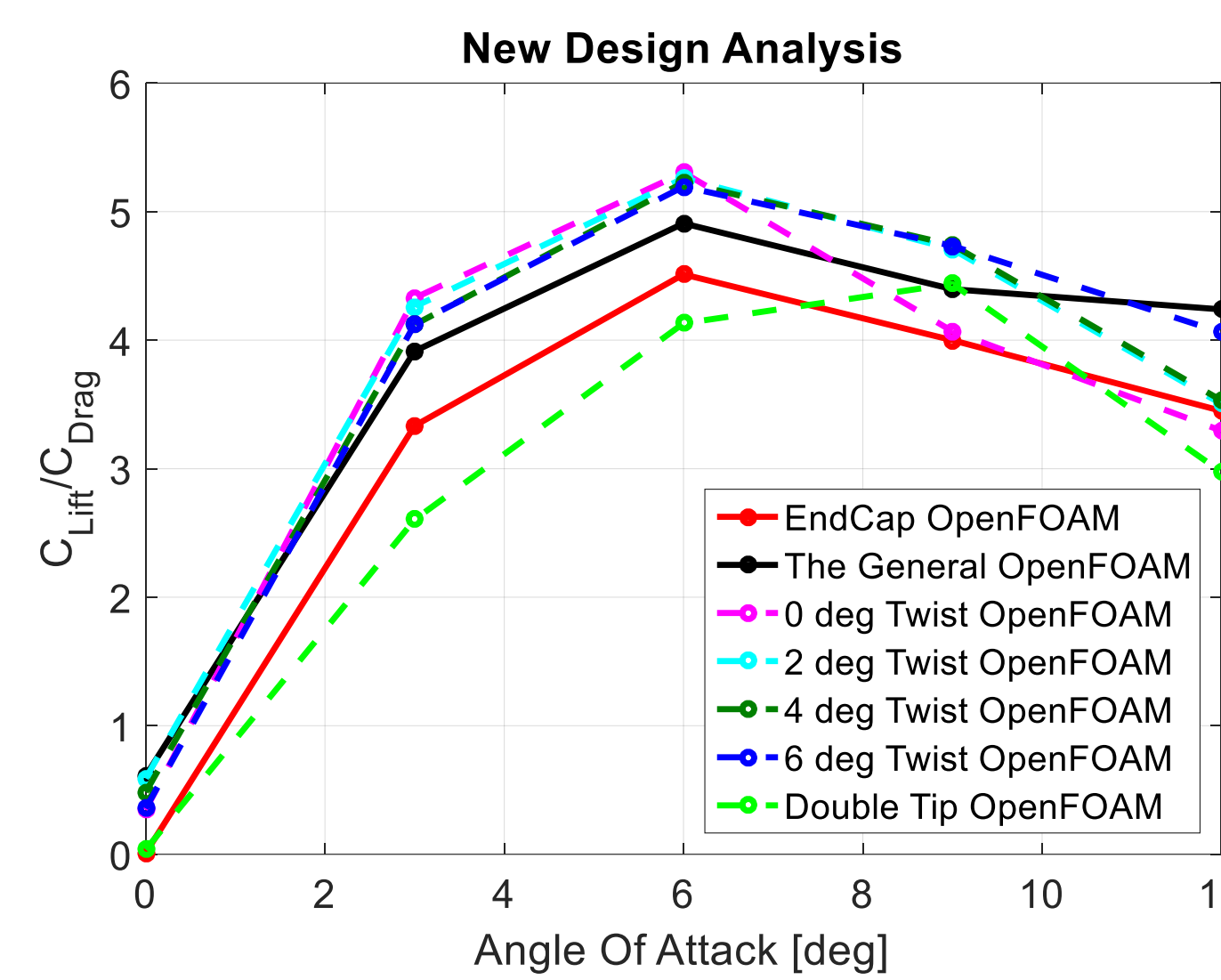

New Design

- Modified general foil
- Tapered at one end
- Twist angle iteration
- Theoretical optimal AoA at 6 degrees

Classic Wingtip Parameters:

- Height
- Cant
- Sweep
- Toe
- Twist
- Taper

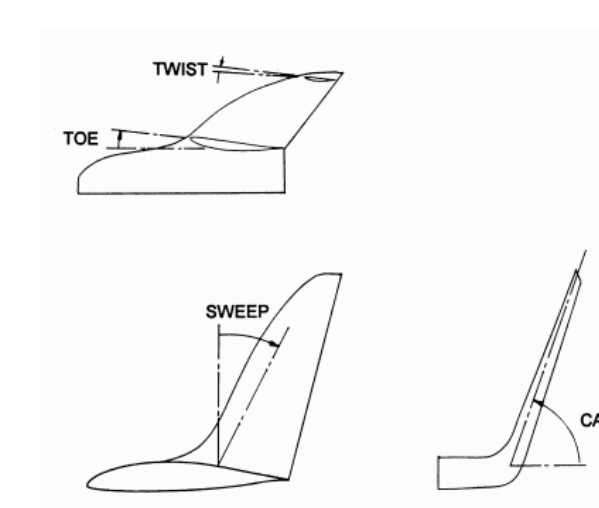

Experimental – Devices tested in the High-Speed Cavitation Tunnel (HiCaT) at Chase Ocean Engineering building

HiCaT

- 36 x 6 x 6 in test section
- Maximum velocity of up to 12 m/s
- Controls pressure and velocity independently
- Measures drag and lift forces on hydrofoils.

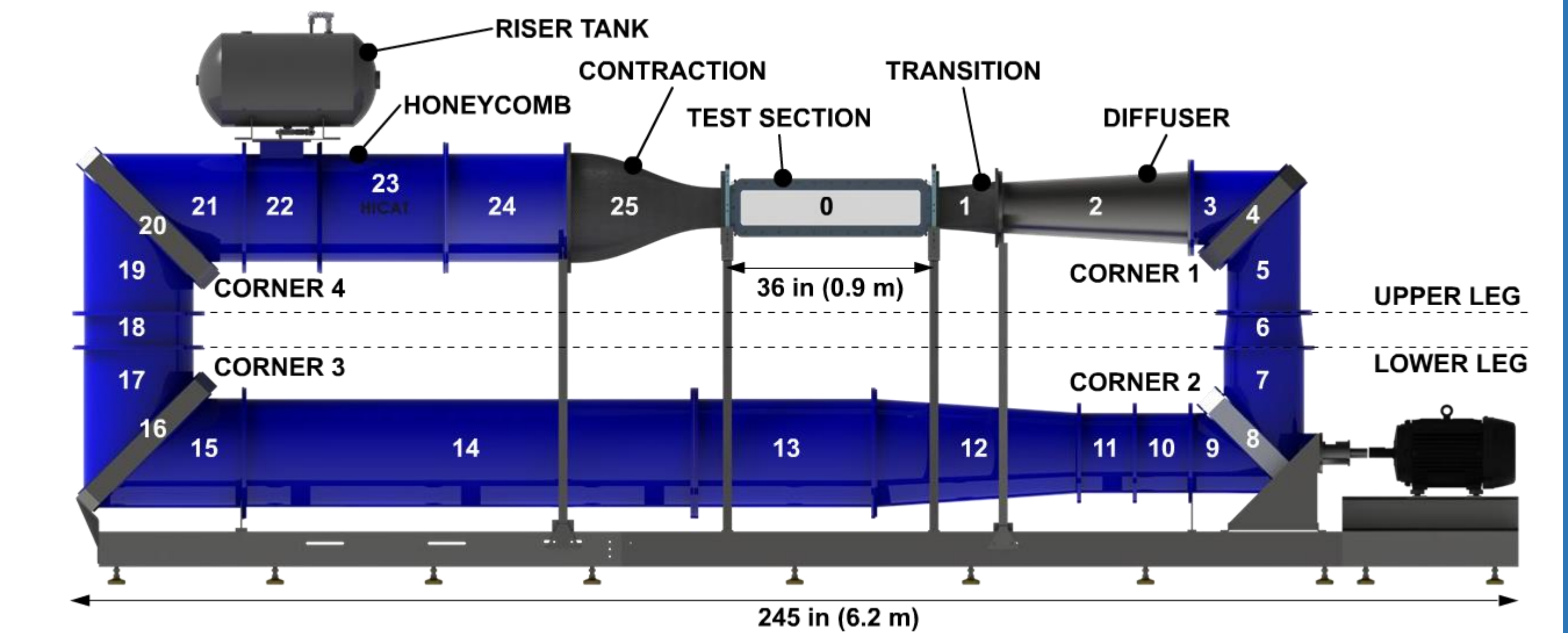

Experimental Test Bed Improvements

1. Drag plate replacement
 - Higher sensitivity
 - Improved resolution
2. Absolute pressure transducer

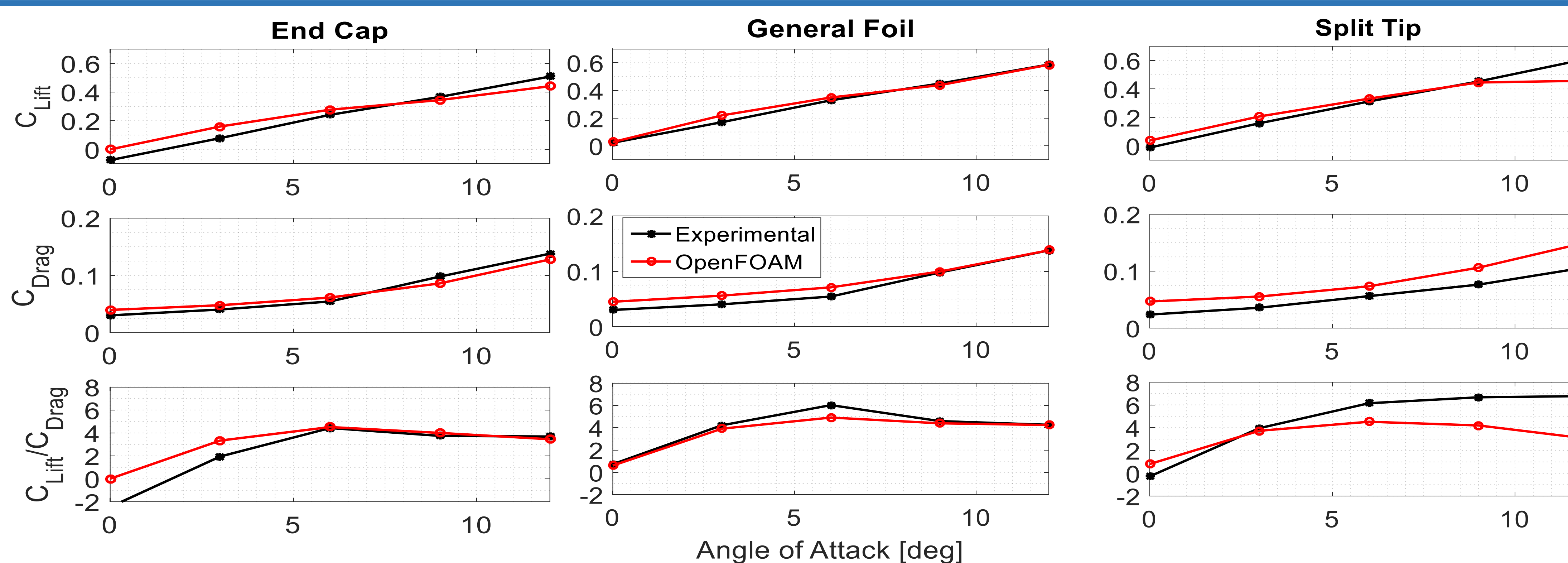
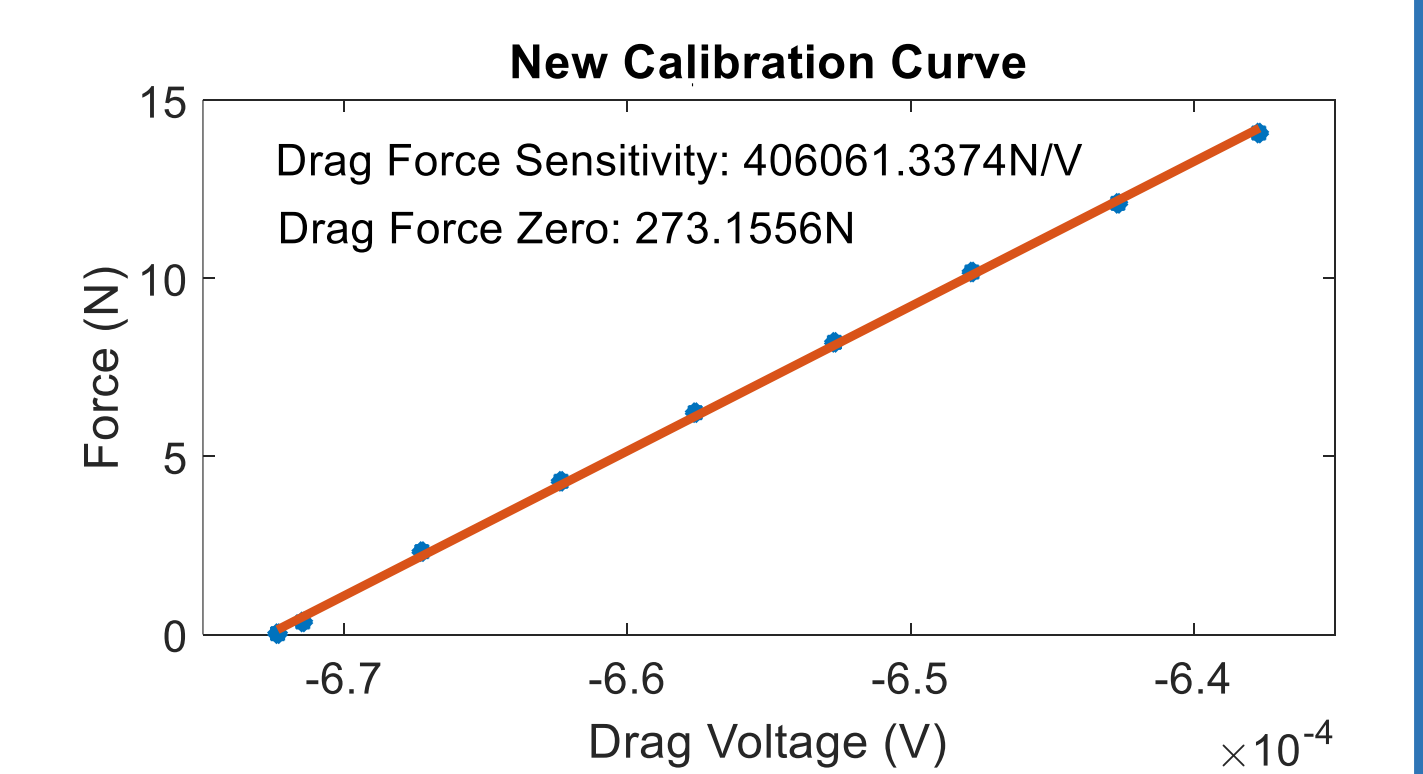
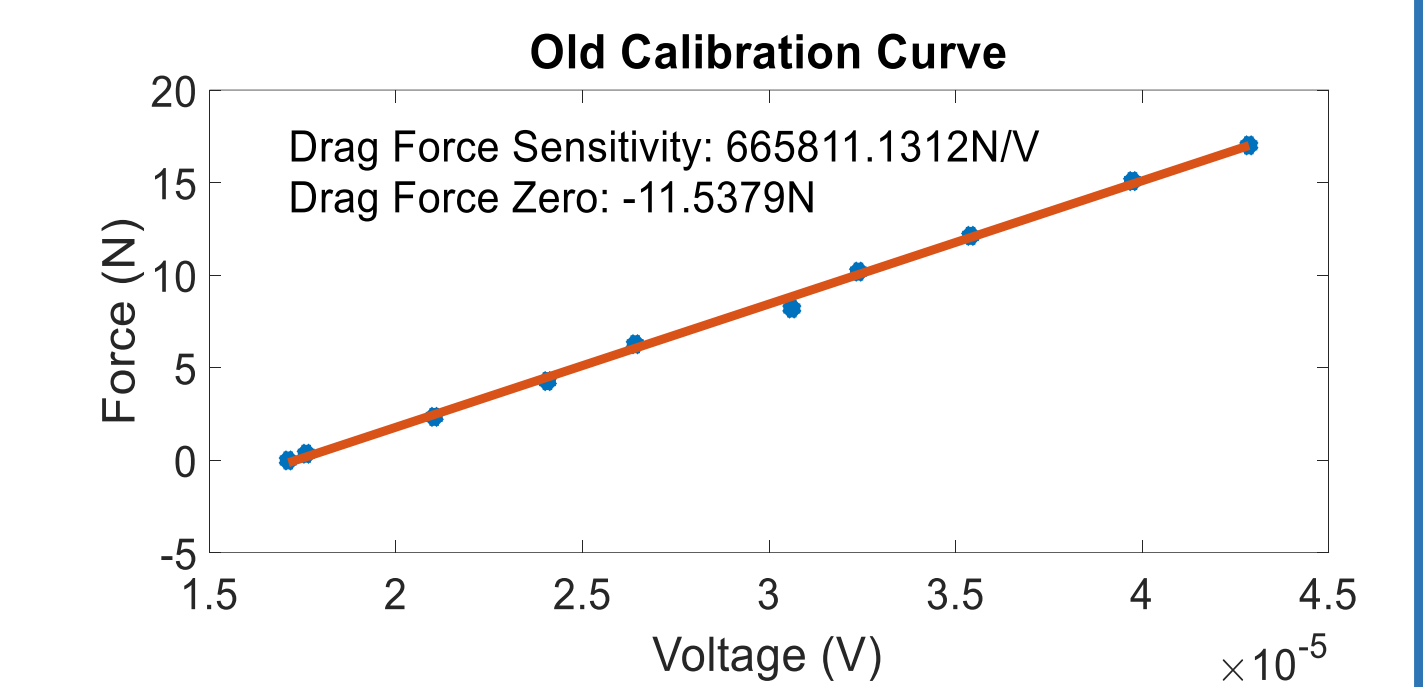

Results:

- General foil – improved performance over the control (end cap)
- Optimal AoA at 6 degrees
- Split tip – yields best results experimentally
- Optimal AoA at 12 degrees

Acknowledgements

Advisors: Martin Wosnik, Ivaylo Nedyalkov
Machining: Scott Campbell, Sheldon Parent
Funding: This work is the result of research sponsored in part by the New Hampshire Sea Grant College Program through NOAA grant # NA10OAR4170082, and the UNH Marine Program.
Other: John Brindley, Jesse Shull, Alexander Larson

