



Semi-Batch Design for the Production of Nylon 6 6

Alison Deyett, Katherine Estep, Alexander Redfearn
Chemical Engineering, University of New Hampshire, Durham, NH 03824



Introduction

Product:

- Standard injection molding grade granulated Nylon 6 6
- For use in the automotive industry

Critical to Quality Variables:

- Molecular Weight: 80,000
- Density: 1140 kg/m³
- Tensile Modulus: 3000MPa under dry conditions
- Impact Strength: 5 kJ/m²

Capacity:

- 100%: 85 million lbs (39 million kg)
- 67%: 57 million lbs (26 million kg)

Market:

- Biggest market is China and Western Europe
- The use of Nylon 6 6 in cars has increased 69% per year between 1960 and 2000

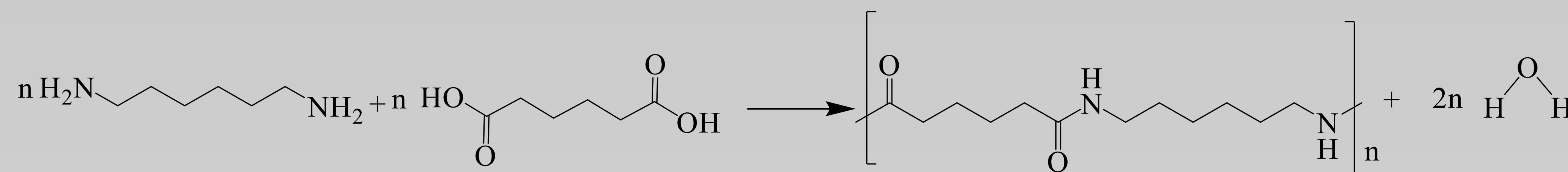

Economic Analysis

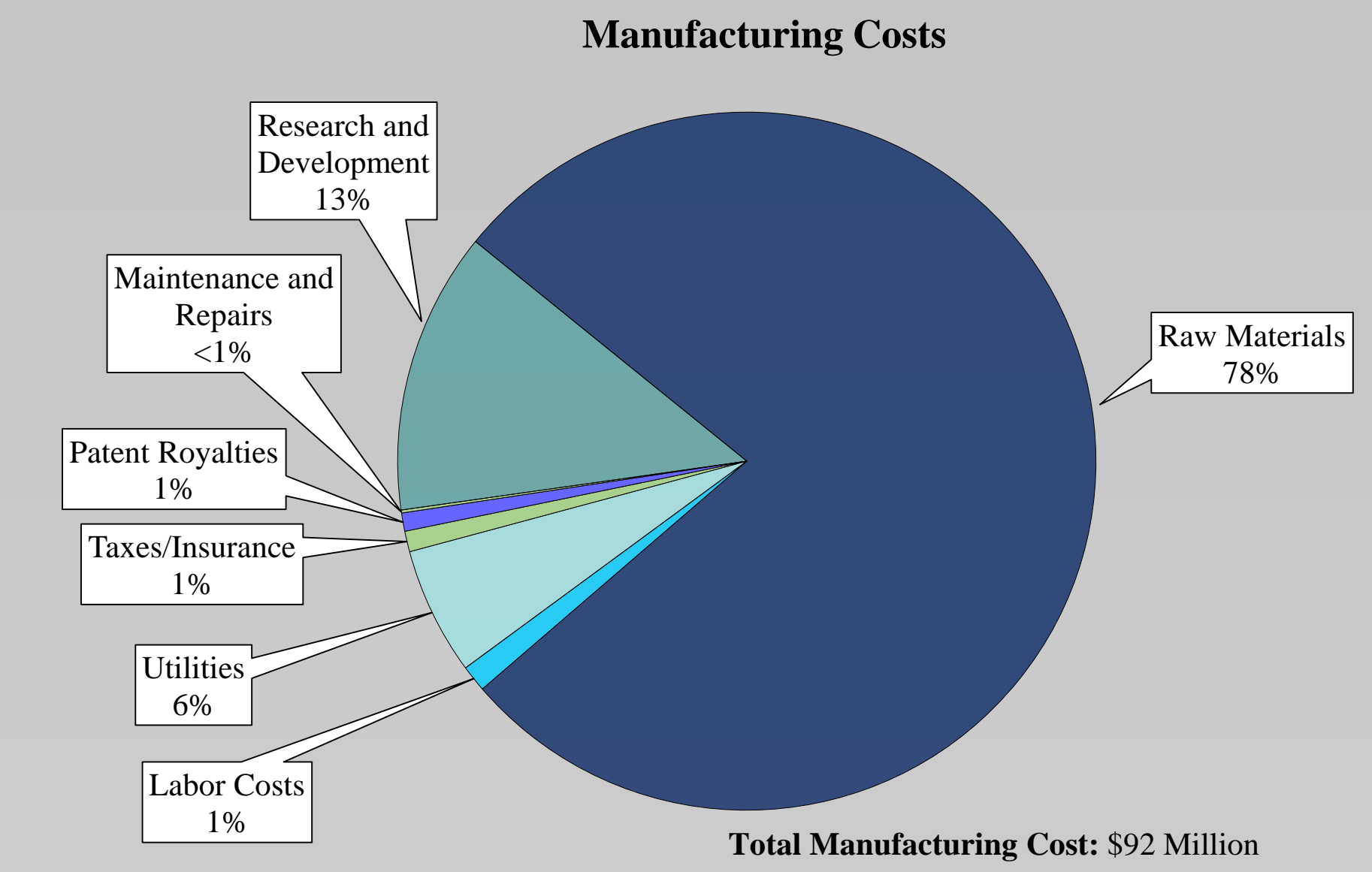
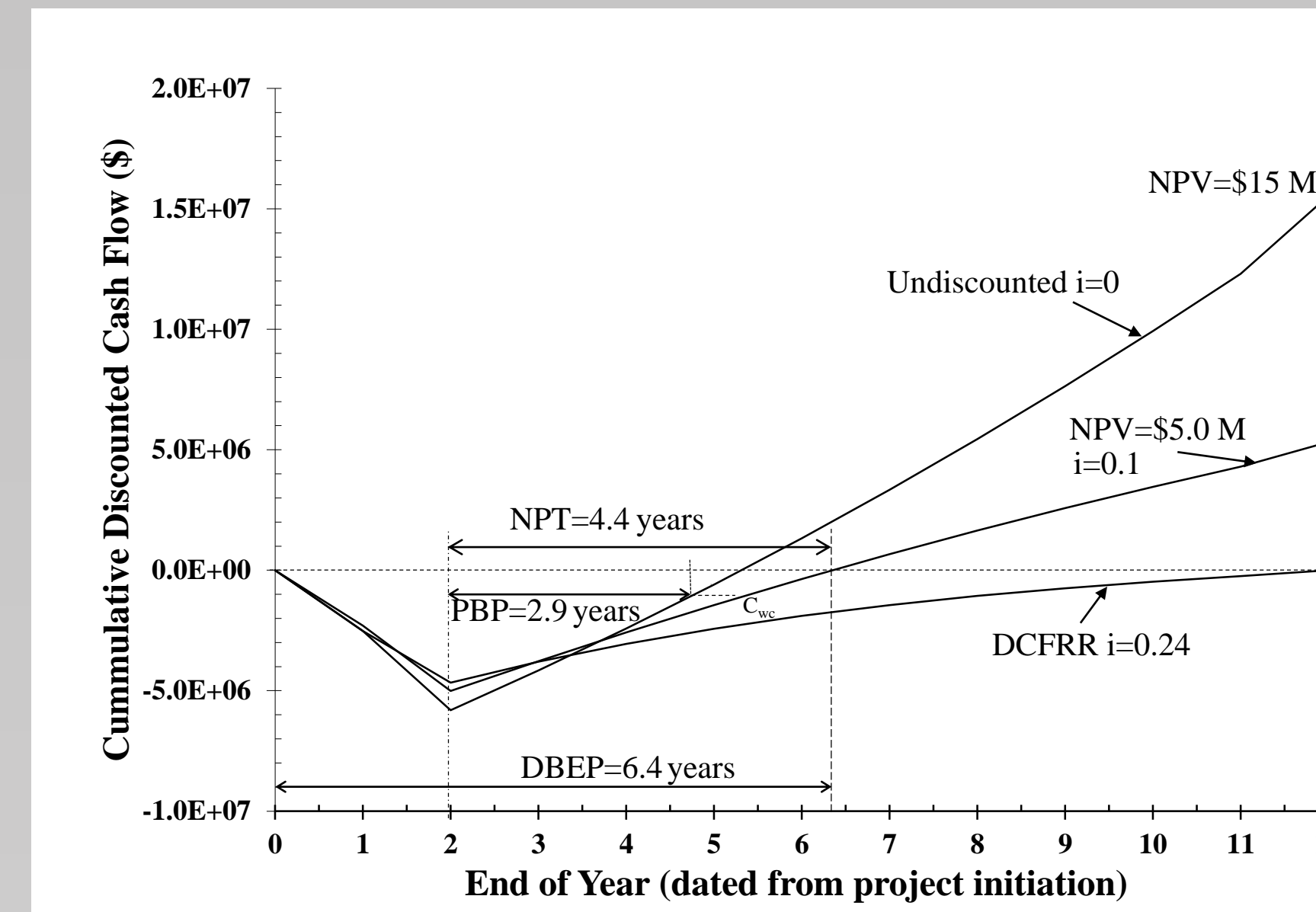
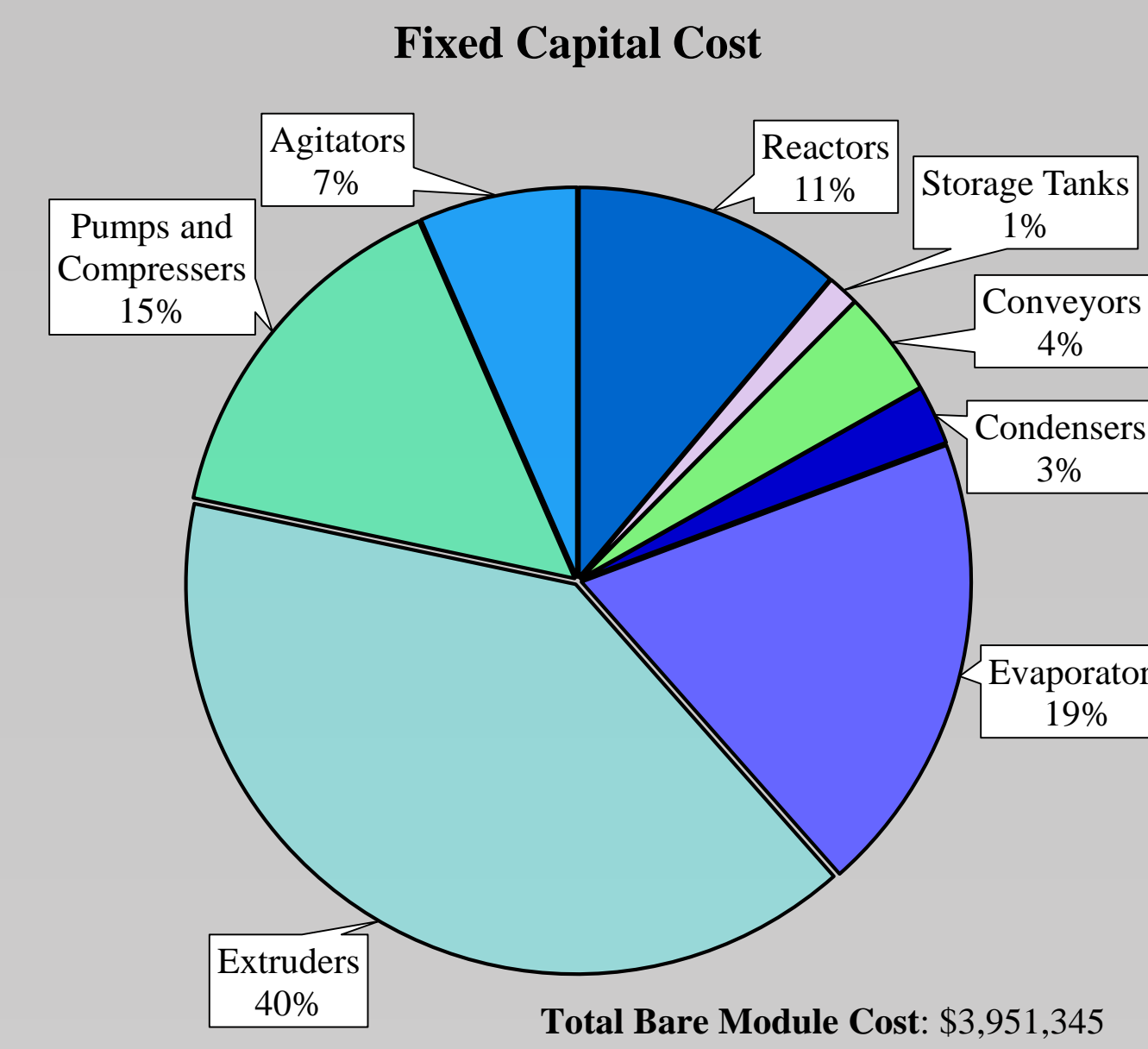

- Grass Roots Cost: \$5.05 million
- Total Capital Investment: \$5.81
- Net Annual Profit \$1.92 million

Process Flow Diagram

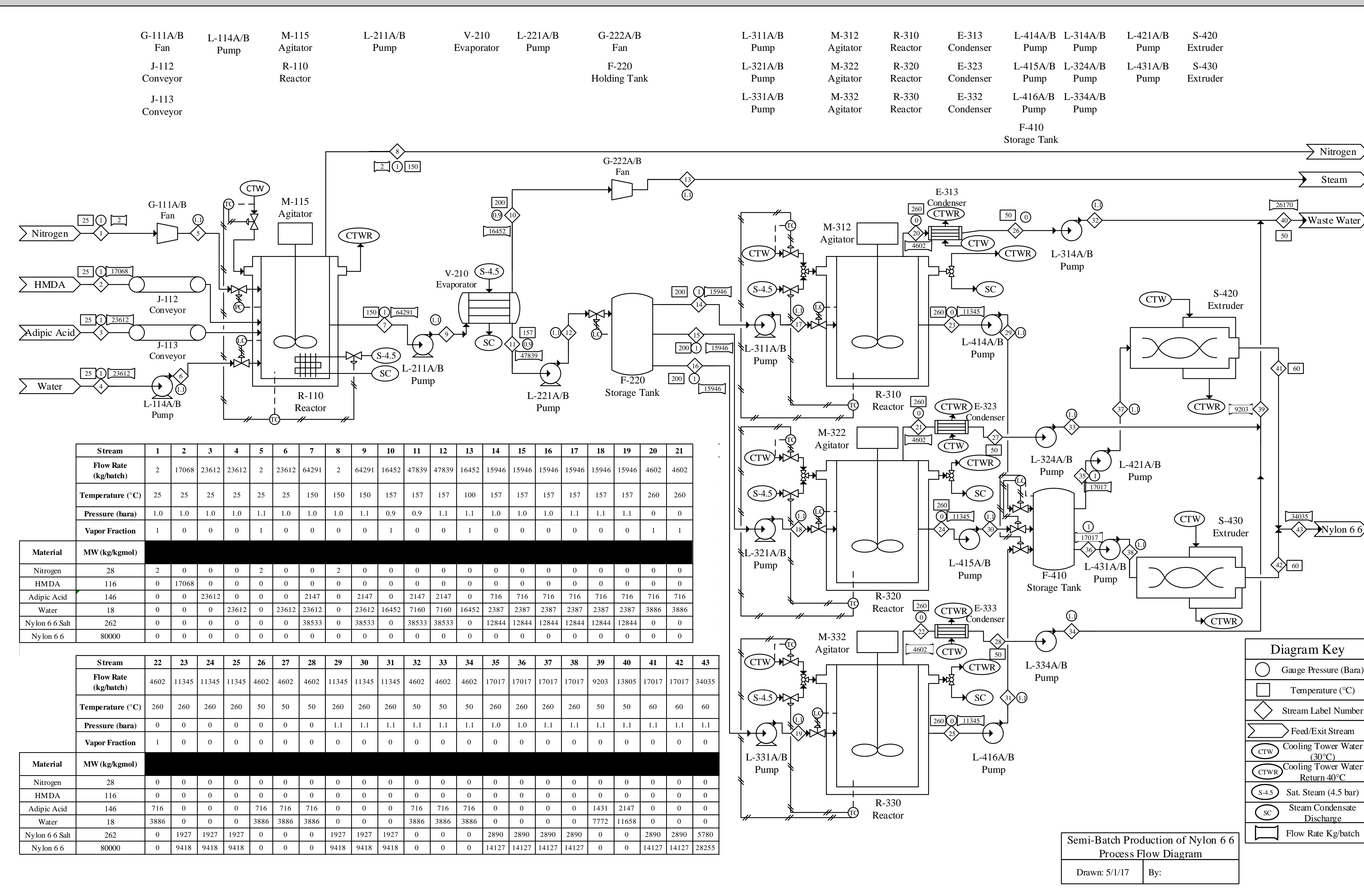

Safety Evaluation

Inherent Safe Design

- 3 polycondensation reactors used
- Control loops regulating pressure, temperature, and level were designed to simplify operator procedures
- Relief valves are installed
- Initial HAZOP Report completed around polycondensation reactors

Relief Valves

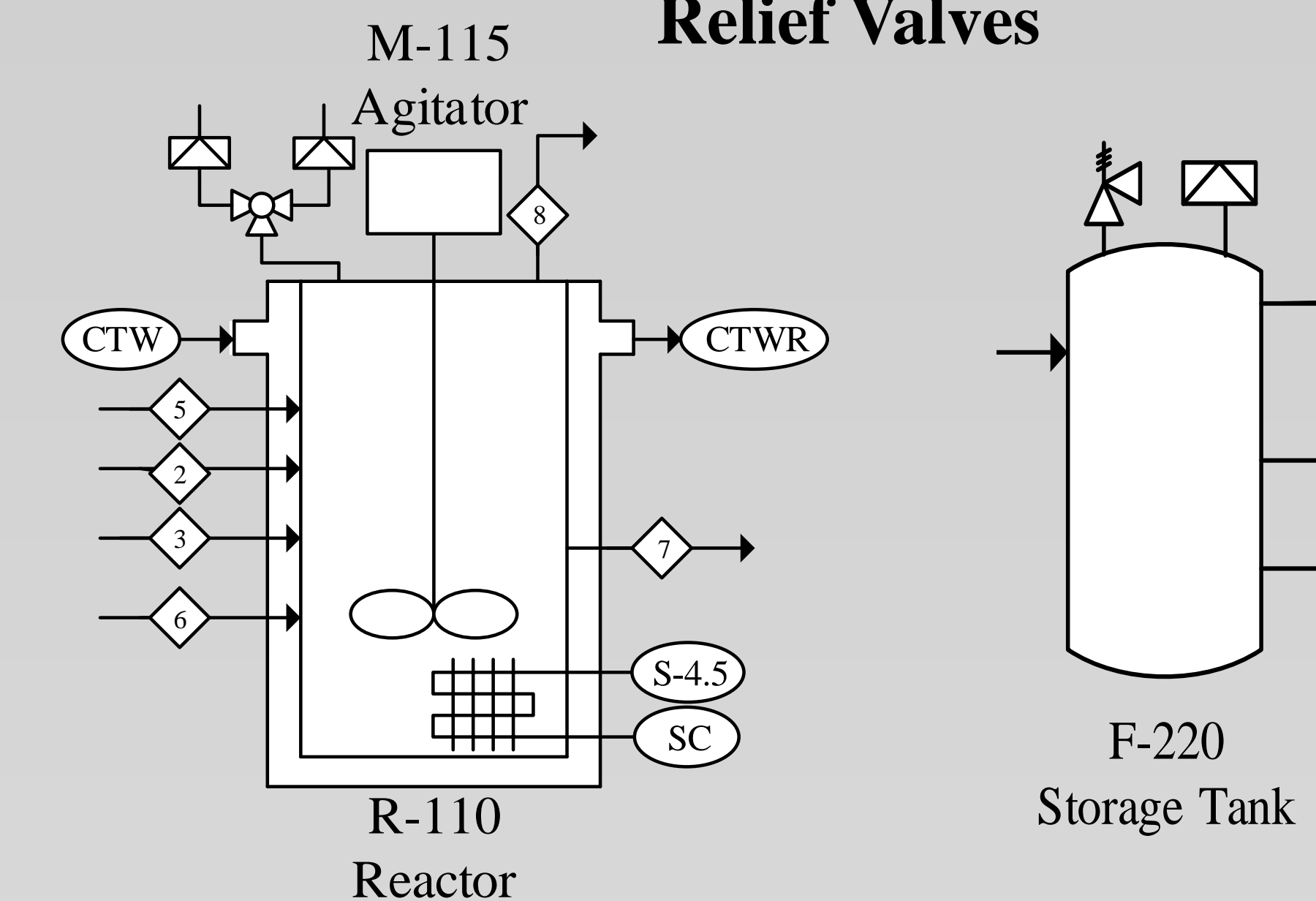

Conclusion

- Plant is a GO
- Net annual profit \$1.92 million with an after-tax rate of return of 49.7%
- DCFRR: 24%
- Control loops and relief valves designed around major pieces of equipment to make the design inherently safe

Acknowledgments

- Our families and friends for their support
- The University of New Hampshire for the Department of Chemical Engineering

References

- UNITIKA LTD., "UNITIKA NYLON66: Standard nylon," [Online]. Available: <https://www.unitika.co.jp/plastics/e/pdf/A125.PDF>. [Accessed 4 April 2017].