

# Rotating Electric Field Ion Mass Spectrograph Instrument Development

Payson Dunn, PMD1016@wildcats.unh.edu, Faculty Advisor: Professor James Clemmons  
Department of Physics and Astronomy, University of New Hampshire



University of New Hampshire  
College of Engineering and Physical Sciences

## Abstract

The work described here develops the ion optics component of an ion mass spectrograph in order to improve its precision and resolution. The instrument, which uses a rotating electric field and a time and position sensitive detection plate to analyze the mass spectra of incoming ions is called REFIMS (rotating electric field ion mass spectrograph). Details of the development are discussed include computer simulations of the ion optics and plans for fabricating and testing physical prototypes. The resulting instrument will be flown on the upcoming Dynamo-2 sounding rocket mission and the way the measurements will be used to answer questions about the ionosphere is presented. Promising early results towards the overall goal of modifying and focusing REFIMS such that it is precise to one atomic mass unit over a range of one to 80 atomic mass units are presented.

## Project Background

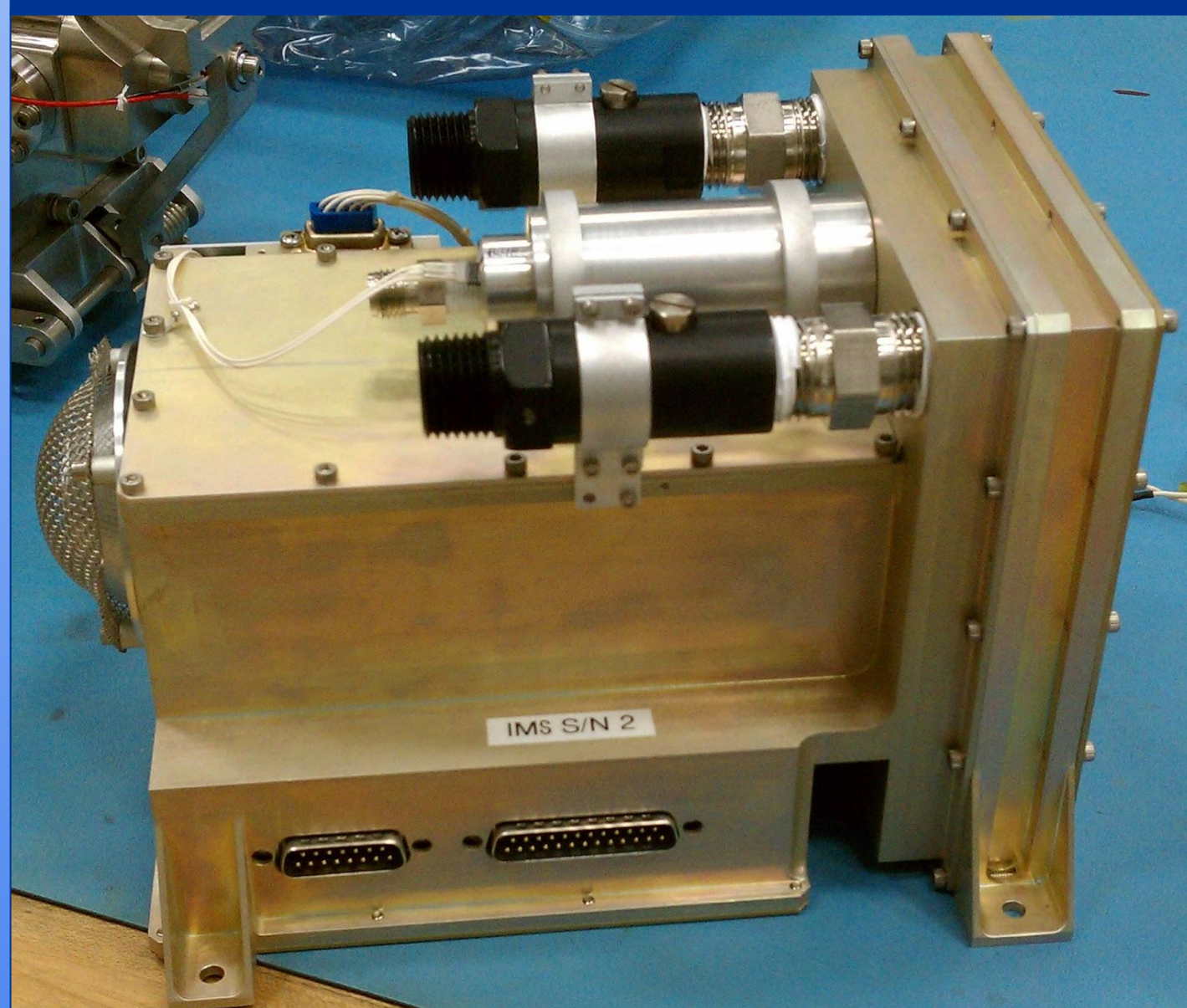

Above is an image of the REFIMS flown on the DYNAMO 1 sounding rocket mission, designed by Professor Clemmons. The goal of the project is to modify the geometry of the ion optics system to be able to accommodate a detection plate with a larger radius, that will increase resolution and sensitivity, and to otherwise improve the instrument.

## Acknowledgements and Citations

I would like to thank Professor Clemmons for taking me on to work on this project, which continues his original research, and for his extensive guidance on the project. His article on REFIMS is cited here:

Clemmons, J. H., and F. A. Herrero. "Mass Spectroscopy Using a Rotating Electric Field." *Review of Scientific Instruments*, vol. 69, no. 6, June 1998, pp. 2285–2291., doi:10.1063/1.1148933.

## REFIMS's Ion Optics System in SIMION

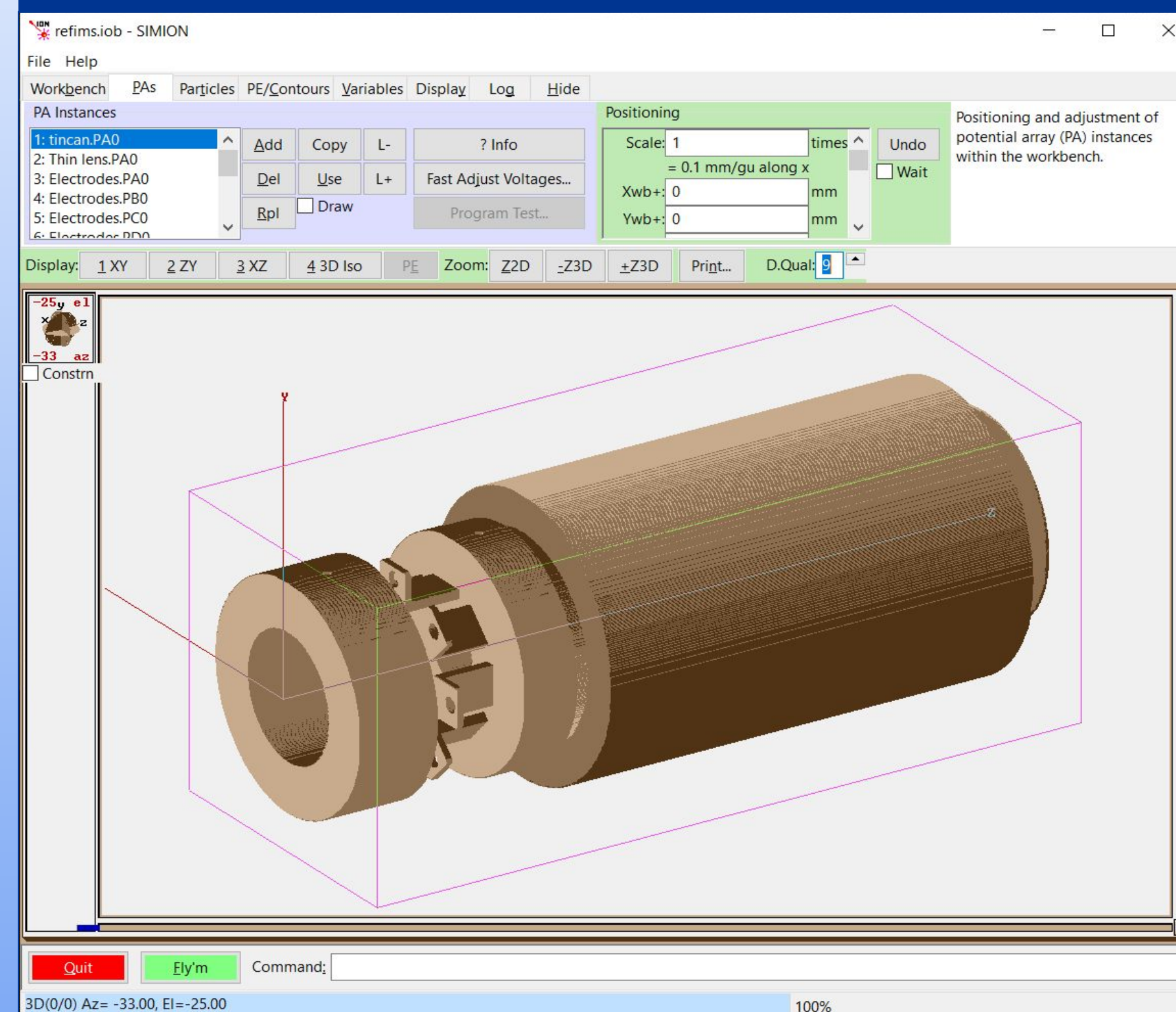

To the left is REFIMS's ion optics system modeled in the SIMION workbench. Normally there would be a 'tin can' kept at ground around the whole apparatus, however it has been left off for demonstration purposes. SIMION allows the user to create STL files in SolidWorks and import them as PA's (Potential Arrays) into SIMION. Those PA's can be arranged in the SIMION workbench to model ion optics systems. SIMION will also calculate the electric potential at every grid point through the relaxation method. Using SIMION, we can simulate what would happen if a change was made to the geometry. The rotating electric field is controlled through supplemental user programming, written in Lua.

## Ion flight trajectories through REFIMS

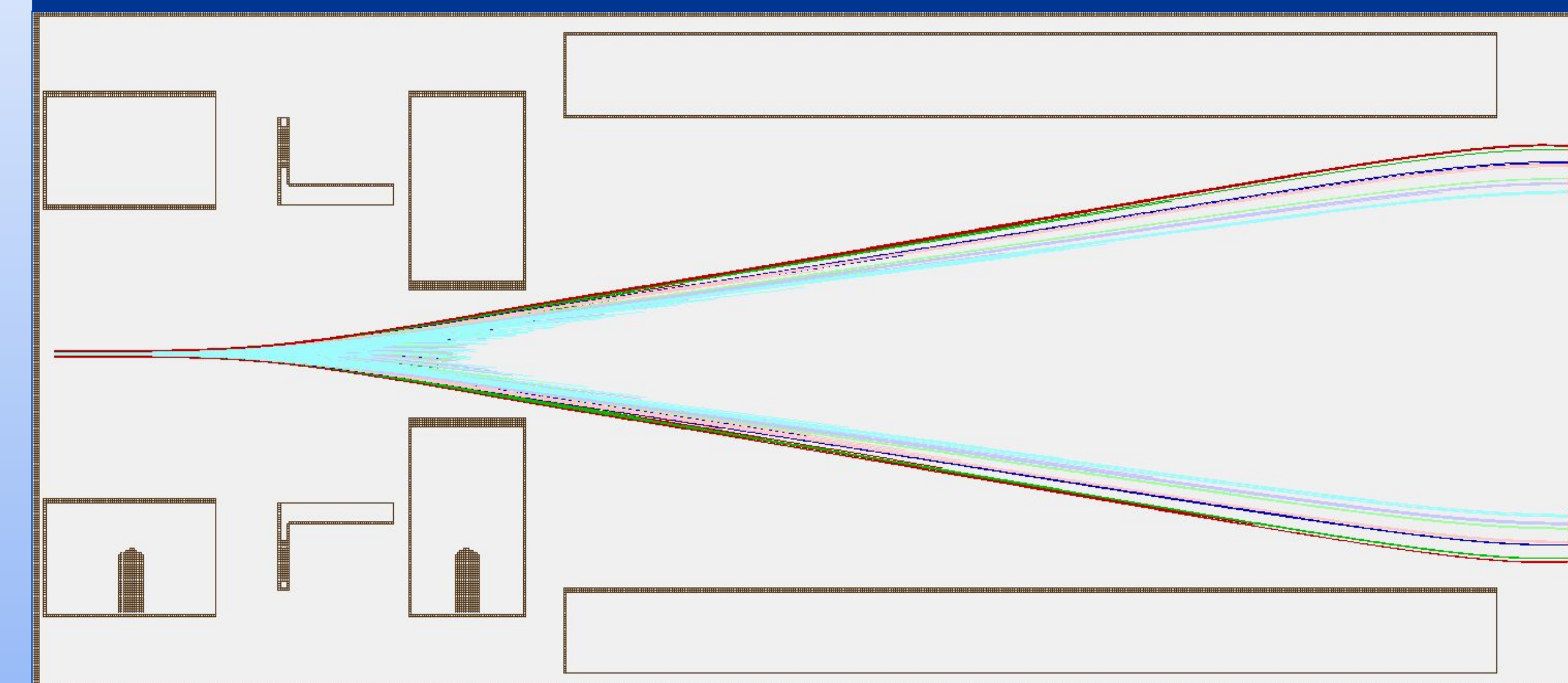

Above is a screenshot of a cross section of REFIMS's ion optics system modeled in SIMION. The colorful lines are the trajectories of ions, color coded by ion species. The spread in the species is due to the heavier species passing through the rotating electric field slower. As the field rotates the force vectors begin to cancel with themselves over time, and the ions are deflected less overall. You will notice this is corrected to some extent by the electromagnetic lensing. The ion trajectories were generated by SIMION.

## Principles of Operation

1. Ions diffuse into the instrument through a small aperture, and are focused into a beam by a series of electromagnetic lenses
2. The more massive ions will be moving slower than the lighter ones, as all of the ions pass through the same electric potential difference. The added energy will make negligible the random atmospheric energies of the ions
3. The beam of ions is deflected by an electric field that is rotating rapidly on the plane normal to the path of the beam
4. After being deflected, the ions are allowed to drift, and are further focused by more electromagnetic lenses
5. The ions are eventually detected by a position and time sensitive detection plate
6. The time at which an individual ion passed through the rotating field can be inferred from its azimuth angle, and by comparing this time to the time of its landing we can infer its velocity, and therefore its mass

## Preliminary Data

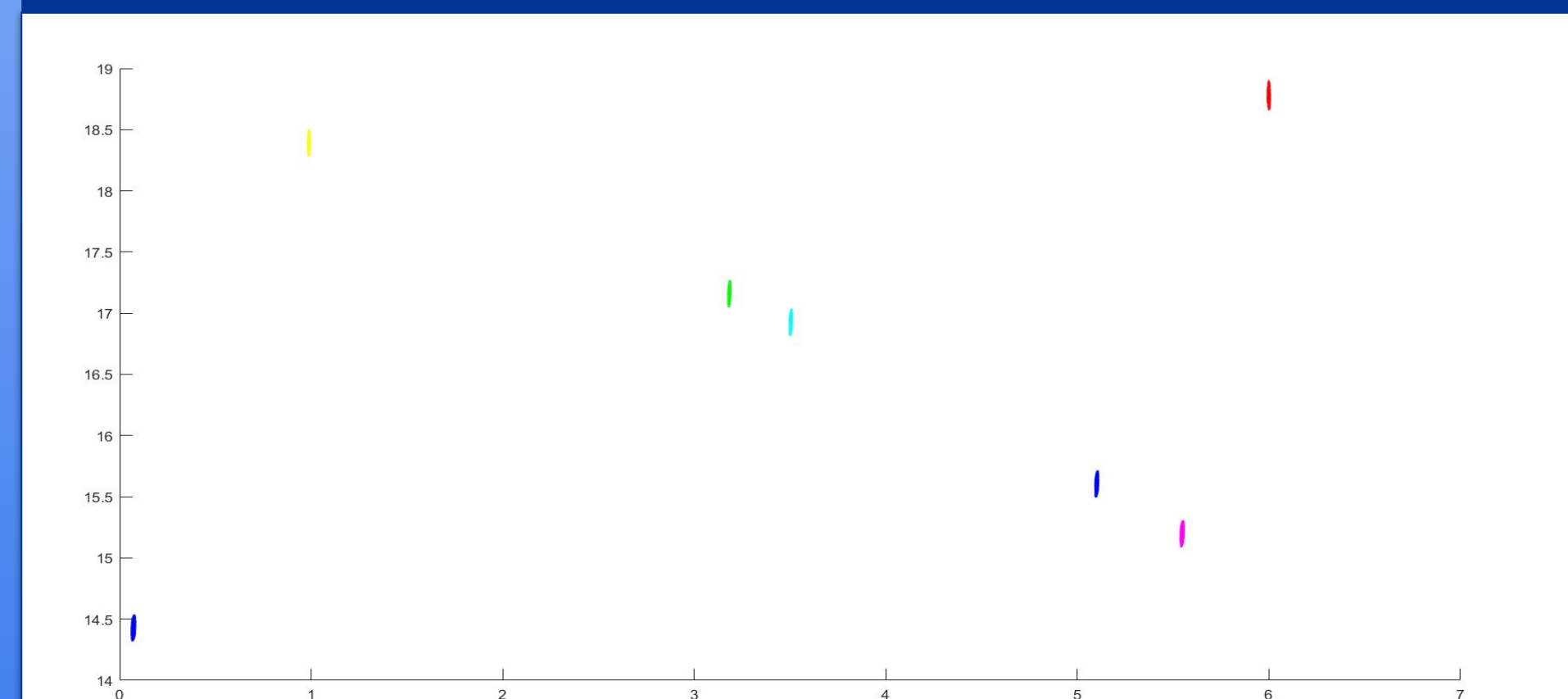

Species	Radius (mm)				Angular Displacement (Radians)			
	Max	Min	Mean	Std	Max	Min	Mean	Std
Hydrogen	17.72	17.51	17.60	0.04	6.00	5.98	5.99	0.0033
Helium	17.35	17.19	17.26	0.03	0.97	0.96	0.97	0.0019
Nitrogen	16.28	16.11	16.19	0.03	3.15	3.46	3.14	0.0018
Oxygen	16.07	15.90	15.98	0.03	3.47	3.47	3.47	0.0019
Nitrogen 2	14.91	14.75	14.82	0.03	5.06	5.05	5.06	0.0023
Oxygen 2	14.55	14.39	14.46	0.03	5.50	5.50	5.50	0.0025
Argon	13.87	13.71	13.78	0.04	0.03	0.02	0.03	0.0029

## Current Progress and Future work

While the project is ongoing, and the model is not as complete as it will be (namely, missing an aperture), relatively few changes have been made to the geometry to increase resolution, and the aperture should be able to focus the ions into a tighter beam than is currently being approximated. To the left is a despun image of data from the latest SIMION trial, which included 70,000 ions ranging from hydrogen at the lightest to argon at the heaviest. The radius of each ion is plotted against its change in azimuth angle. As you can see, each species (denoted by color) is very well separated, and this can be confirmed by consulting the summarizing statistical information in the table to the left. You may notice that hydrogen (red) and argon (black), seem out of place. This will be easily fixed by decreasing the angular velocity of the rotating electric field, which should also have an effect of increasing the angular focus. (See Ion Flight Trajectories through REFIMS.) To continue the project I will model an aperture for REFIMS in SIMION so that the ion beam will be more realistic. Then I will continue modifying the electrode geometries to see if I can improve the focus even more. Eventually we will move to testing physical prototypes.