



Marine and Naval Technological Advancements for Robotic Autonomy (MANTA RAY)

Sustainable Safe Whale Tagging (SWaT) with Power-Efficient Sensor Telemetry



Project Advisors: Dr. May-Win Thein, Dr. Edward Song
 Team Members: Paxton Dionne, Alexander Watkins, Nicolas Zerbinopoulos
 Department of Electrical Engineering, University of New Hampshire, Durham, NH 03824



Introduction

The Safe Whale Tagging (SWaT) initiative's goal is to provide a safe and affordable way to tag and track whales. SWaT is an interdisciplinary project, featuring Mechanical Engineers, Ocean Engineers, and Computer Scientists.

Problem Statement

Current whale tags use barbed spears, darts, or suction cups to attach to the whale. Spears and darts pierce the skin of the whale and can cause health complications for the whale, potentially even death. Suction cups are far less harmful, but current non-invasive designs are far more expensive than dart or spears, making them inaccessible. The goal is to create a non-invasive tag which collects the data that Marine Biologists want to have on whales, at the cost of a modern dart or spear tag.

Methodology and Innovation

Within the Electrical and Computer Engineering portion of the project, our goal was to create a sensor payload which would meet the requirements of a modern tag for a fraction of the cost of current alternatives. The sensor requirements were decided by researching what current tags record and speaking with Marine Biologists to determine what data they would want recorded for whales. Additionally, given the extended duration that whale tags need to operate on battery power, creating a design that would draw a low amount of power became a priority.

Progress

The design process required many iterations of PCB before getting the completed state, with a total of five boards being designed and two being built. Early designs featured the ATMEGA328P, which was later changed to the ESP32 to reduce the number of additional components. Switch the boards allowed for the Real Time Clock, USB to UART controller, button cell battery, and crystal oscillators to be consolidated into a single chip, making the design much smaller. The final iteration of the design features GPIO pins for future teams to build from and expand functionality as needed. Our block diagram is displayed in Fig. 1.

Novelty

As previously mentioned, two major goals of this design were to make the design cheap and to make the design power efficient. We able to achieve a very low power draw by having the device enter a low power mode when measurements aren't being taken. Fig. 2 shows the difference in power consumption between when the device is measure and when the device is not measuring. Additionally, Fig. 3 shows what percentage of time the board will be in each state. With the board spending most of its time in low power mode, which takes significantly less energy, we can greatly extend the time that we are tracking the whale. We also succeeded in creating a cheap design with our entire the cost of our sensor payload falling within the average cost of a dart tag, demonstrated in Fig. 4. The breakdown of the total cost is shown in Fig. 5.

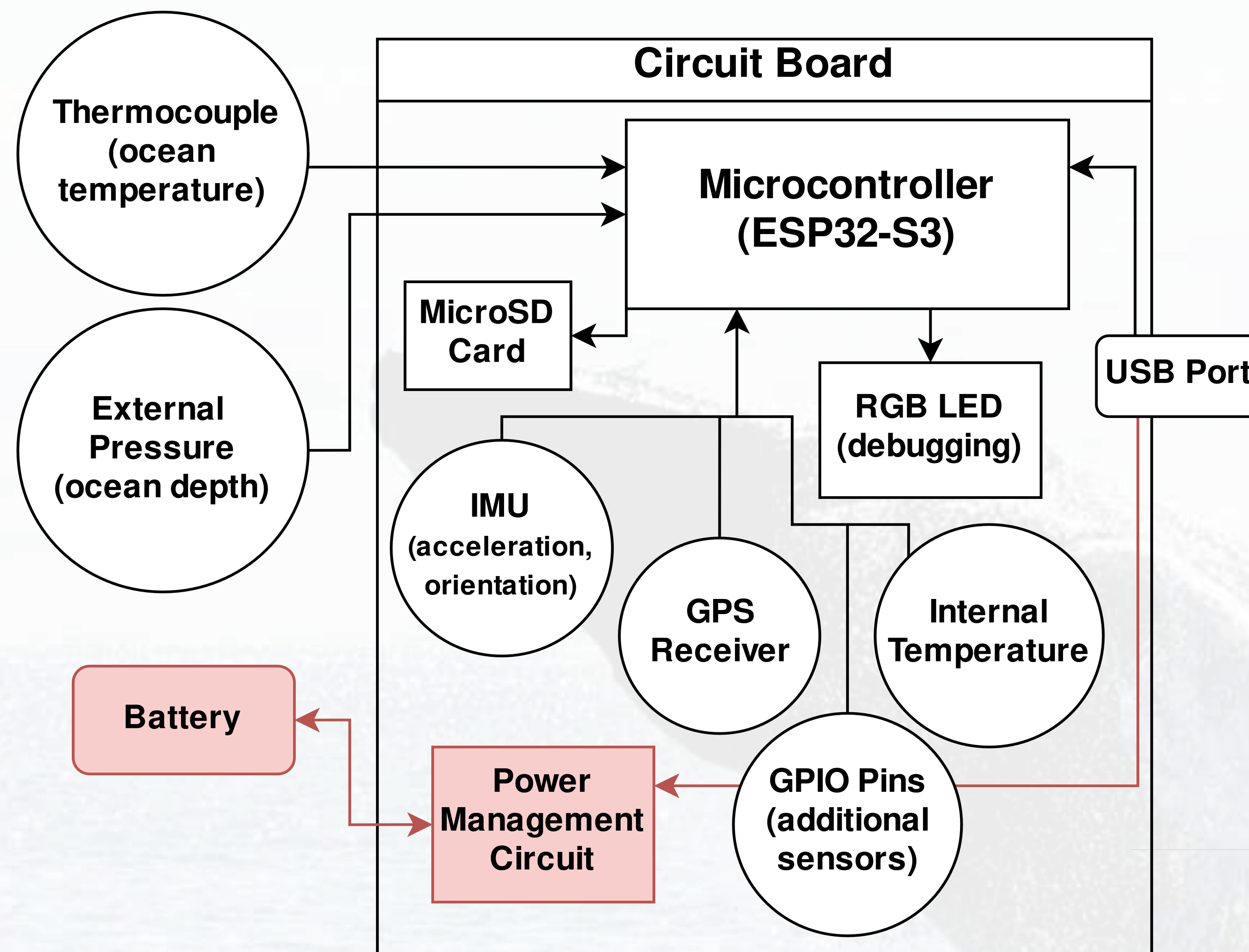

Figure 1. Sensor Payload Final Block Diagram

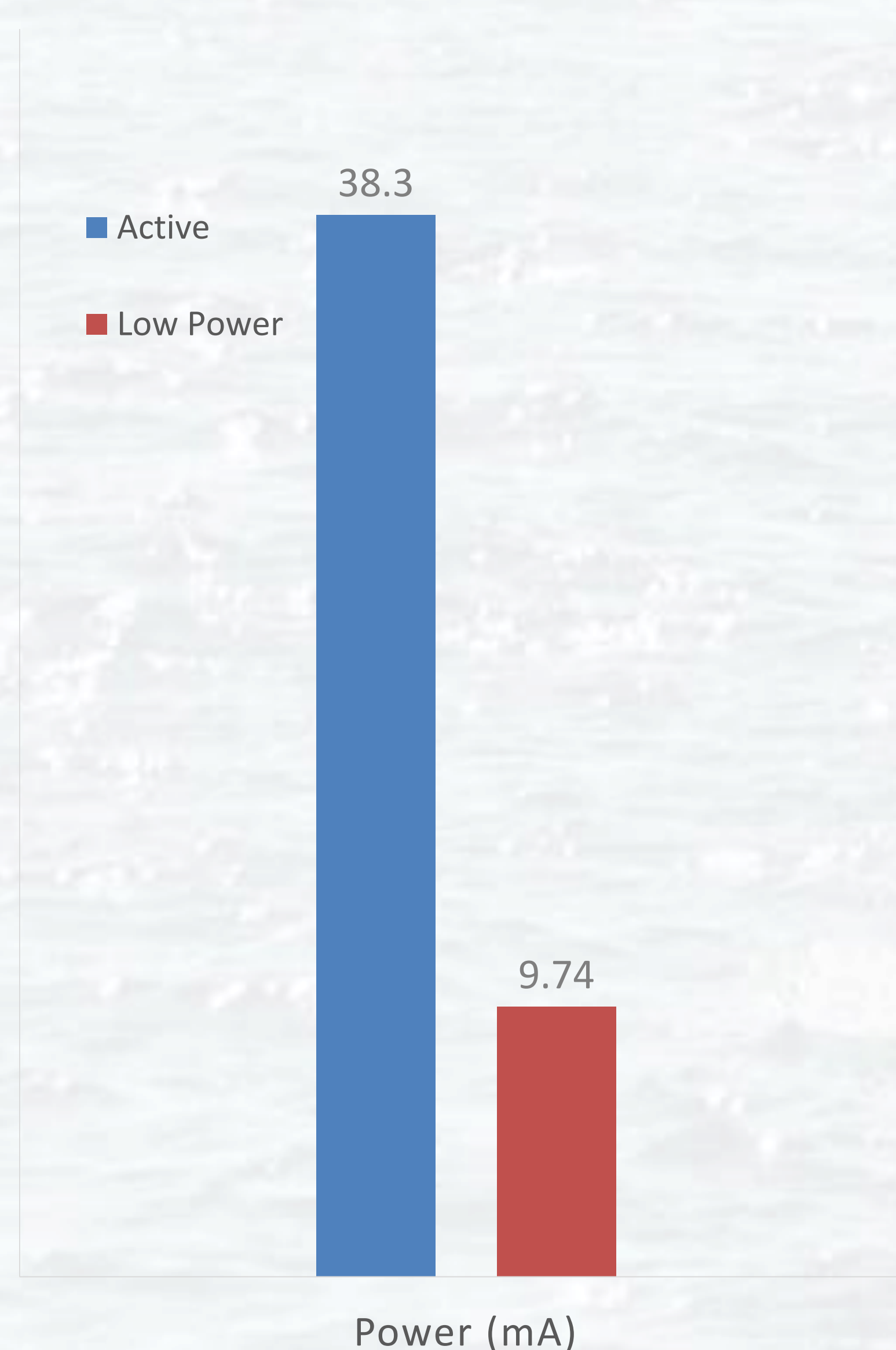

Figure 2. Difference in Power Consumption for Different Modes

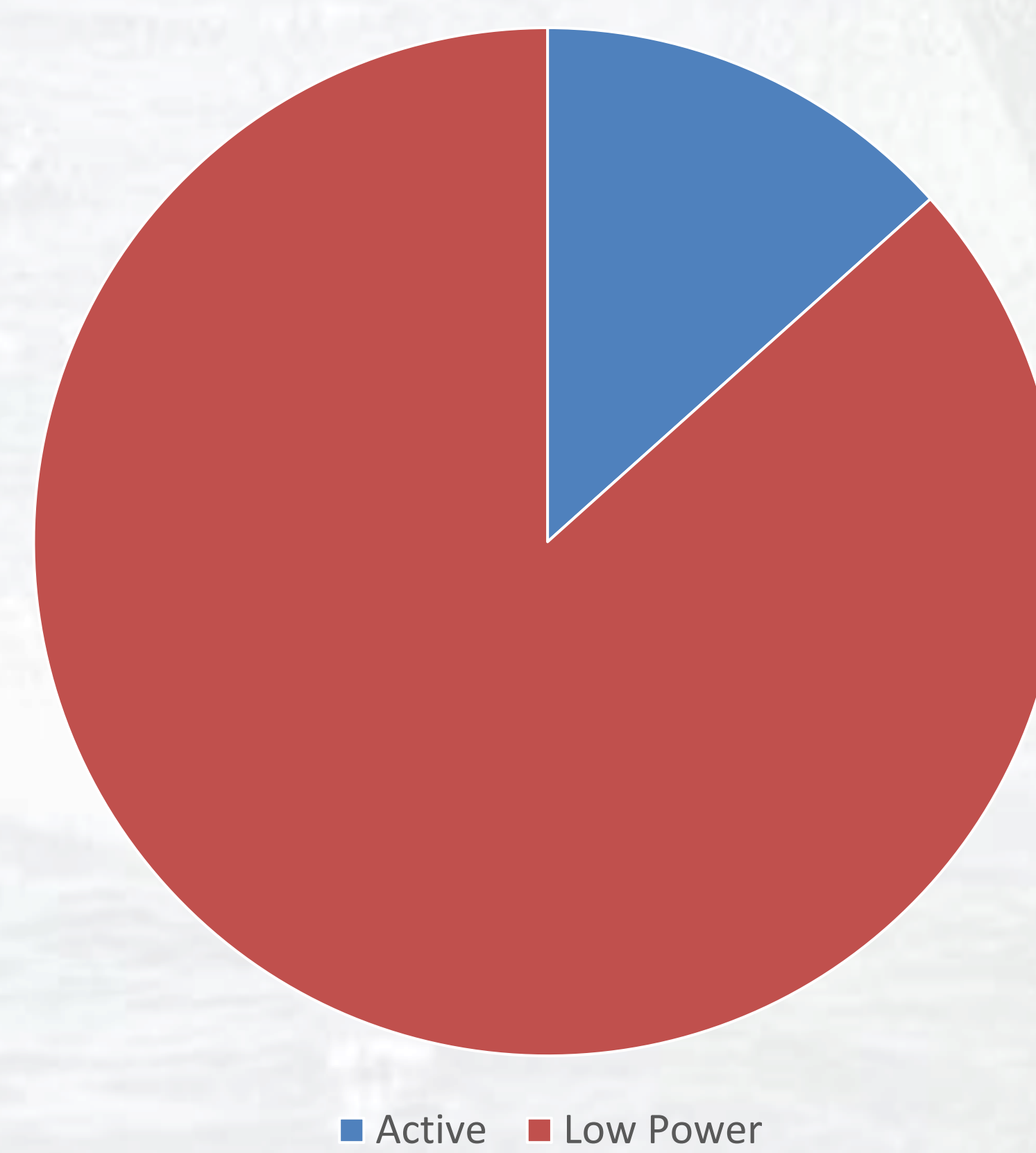

Figure 3. Percentage of Time Spent in Each Mode

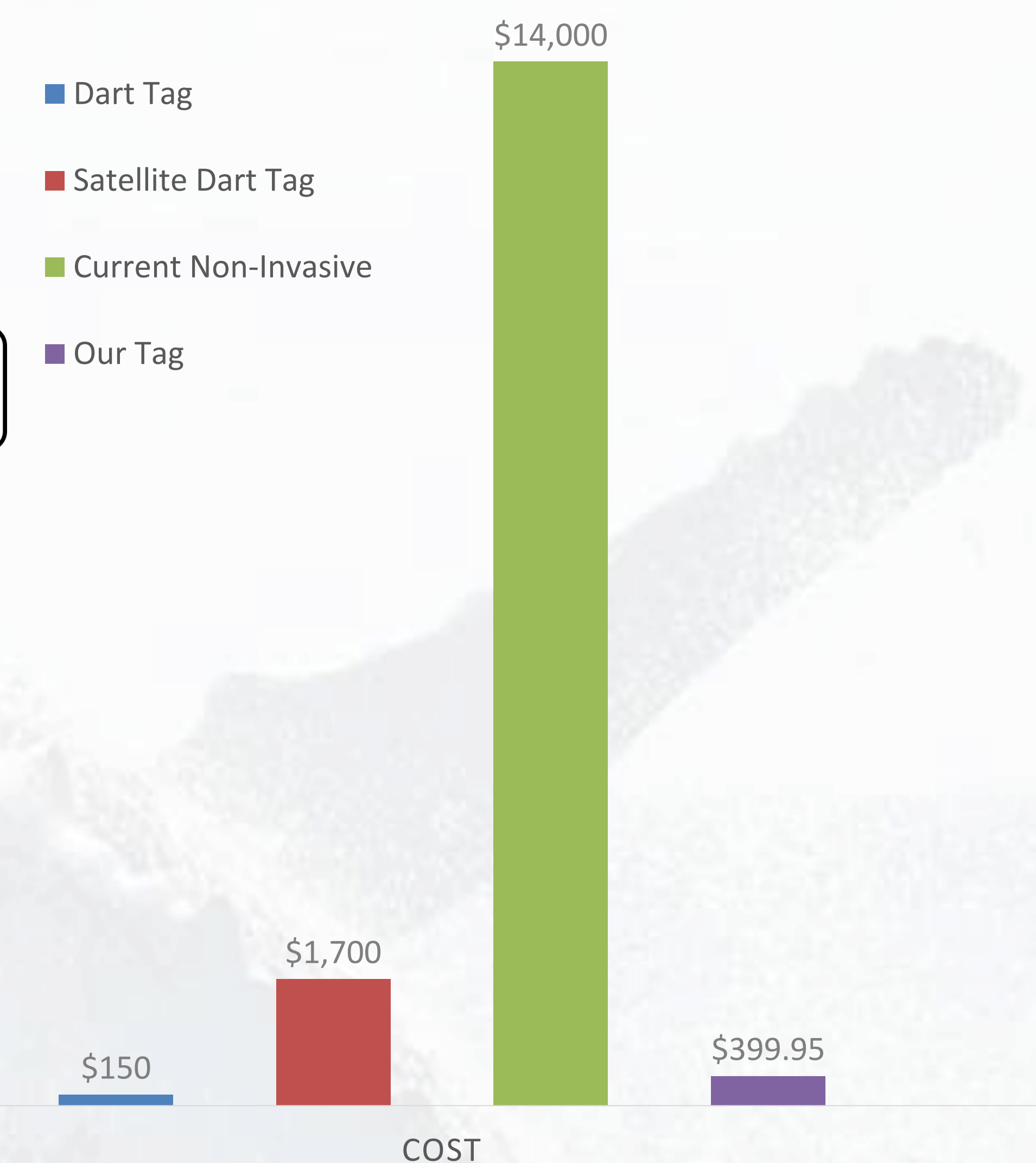

Figure 4. Comparison of Cost to Other Modern Whale Tags

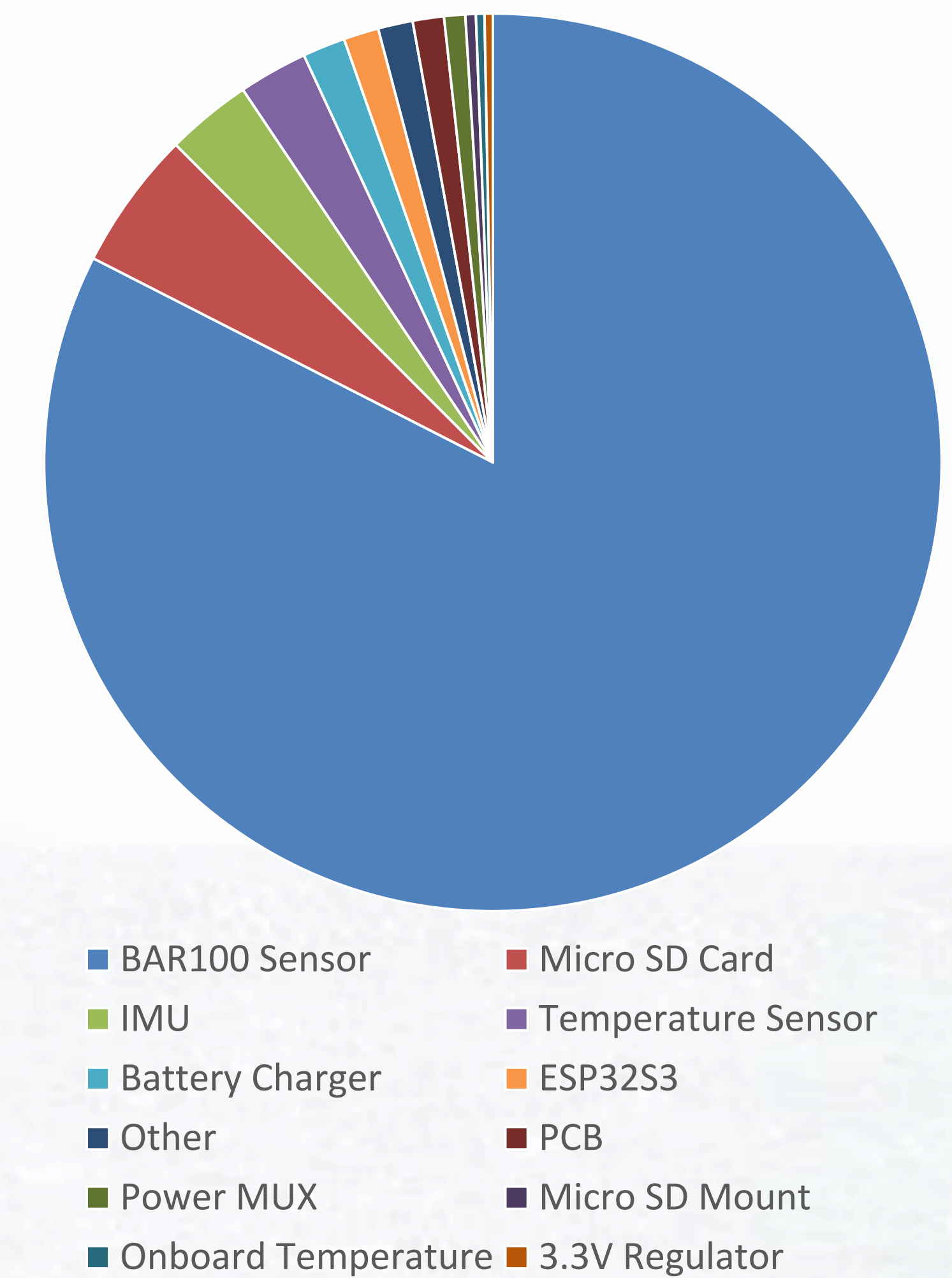

Figure 5. Cost Breakdown by Components

Future Work

The design is complete with regards to what the goals for this year were, with the final step being to combine the sensor payload with the hull designed by the mechanical engineers. There were additionally functionalities that were not necessary but will improve the design such as a method for detecting salinity levels and a GPS module to allow for retrieval of the tag. With this project being an iterative one, a document containing the knowledge collected will be created and recommendations for future teams to focus on will be provided. The board has been designed with GPIO pins so that it is expandable, and future teams will be able to adapt the base design to whatever emerging needs they have.

Contact Us!

If you wish to contact any of us, scan the QR code to visit our website and see our contact information!



References and Acknowledgements

[1] P. D. Schiavone et al., "X-HEEP," *Proceedings of the 20th ACM International Conference on Computing Frontiers*, pp. 379–380, May 2023. doi:10.1145/3587135.3591431
 [2] T. Pangaribowo, W. Mulyo Utomo, A. Abu Bakar, and D. Shidqi Khaerudin, "Battery charging and discharging control of a hybrid energy system using microcontroller," *Indonesian Journal of Electrical Engineering and Computer Science*, vol. 17, no. 2, pp. 575–582, Feb. 2020. doi:10.11591/ijeecs.v17.i2.pp575-582
 [3] R. D. Andrews et al., "Best practice guidelines for cetacean tagging," *IWC Journal of Cetacean Research and Management*, vol. 20, no. 1, pp. 27–66, Jan. 2019. doi:10.47536/jcrm.v20i1.237
 [4] A. Stimpert, D. Mattila, E. Nosal, and W. Au, "Tagging young humpback whale calves: Methodology and diving behavior," *Endangered Species Research*, vol. 19, no. 1, pp. 11–17, Oct. 2012. doi:10.3354/esr00456
 [5] D. M. Palacios et al., "A satellite-linked tag for the long-term monitoring of diving behavior in large whales," *Animal Biotelemetry*, vol. 10, no. 1, pp. 1–17, Aug. 2022. doi:10.1186/s40317-022-00297-9
 [6] Y. Rong, S. Nordholm, and A. Duncan, "On the capacity of Underwater Optical Wireless Communication Systems," *2021 Fifth Underwater Communications and Networking Conference (UComms)*, pp. 1–4, Aug. 2021. doi:10.1109/ucomms50339.2021.9598156
 [7] "facts about satellite tagging dolphins and whales," *IFAW*. <https://www.ifaw.org/journal/satellite-tags-dolphins-whales>
 [8] "Cetacean - Wildlife Computers Inc.," *Wildlife Computers Inc. - Innovative Tags for Innovative Research*, Apr. 10, 2023. <https://wildlifecomputers.com/qr/cetacean/>
 [9] M. S. Riker, "Tagging Whales Tells Researchers 'The Story Of The Whole Ocean,'" *Honolulu Civil Beat*, Feb. 26, 2023. <https://www.civilbeat.org/2023/02/tagging-whales-tells-researchers-the-story-of-the-whole-ocean/>
 [10] N. E. Hussey et al., "Aquatic Animal Telemetry: A panoramic window into the Underwater World," *Science*, vol. 348, no. 6240, pp. 1–11, Jun. 2015. doi:10.1126/science.1255642
 [11] H. Yoshida et al., "Study on land-to-underwater communication," *2011 The 14th International Symposium on Wireless Personal Multimedia Communications (WPMC)*, Brest, 2011, pp. 1-5.13

Special Thanks to:
 Dr. May-Win Thein – Project Advisor, Dr. Edward Song – Departmental Advisor, Dr. Karl D. Brommer – Technical Advisor