

## INTRODUCTION

Energy costs in New Hampshire is higher than the national cost, at 23.33¢ per KWH compared to the national average of 16.73¢ per KWH.

Electricity consumption is high in New Hampshire both during summer-time and winter-time due to plug in heaters/AC units respectively.

Developing something that could help with monitoring this power consumption can help save on utilities bills at the end of the month.

## OBJECTIVES

### Our project is:

- A power strip able to monitor power consumption
- Able to turn on/off each individual outlet remotely
- Be user-friendly to install
- Have a user-friendly interface that will display all collected data and controls

Power strips that can measure voltage or allow for a timer to be set to turn off do already exist, but no product incorporates power monitoring, remote controls, mobile user interface, and at a lower cost.

Our power strip features 8 outlets all wired together with 8-gauge wires allowing for higher amperage applications.

## CIRCUIT DIAGRAM

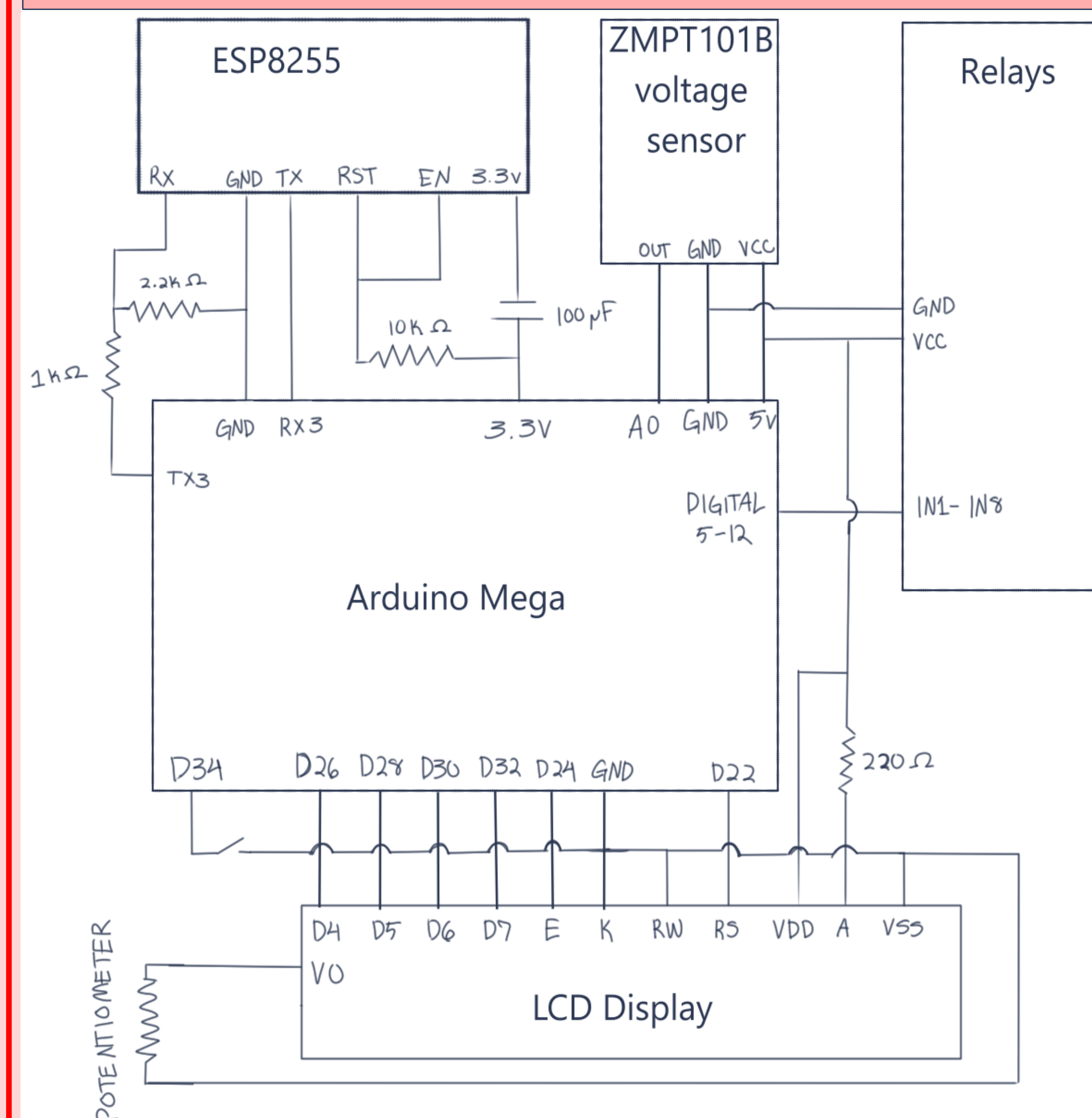

## METHOD

### Hardware

- Arduino equipped with an ESP8255 module for Wi-Fi communications
- 3 AC voltage sensor modules
- 8 channel relays allowing for the user to turn on and off outlets from the user interface
- 8 outlets and wires to provide power to the power strip
- A 3D printed box to house the power strip components

### Software

- Android application (user interface) equipped with a Firebase backend serving as the user interface
- Arduino code allowing for data collection, toggling relay switches, and communication to and from the user interface
- Node.js server that will act as an intermediate between the ESP8266 Wi-Fi module and Firebase backend data base

The figure below described the data flow from the power strip to the user interface.

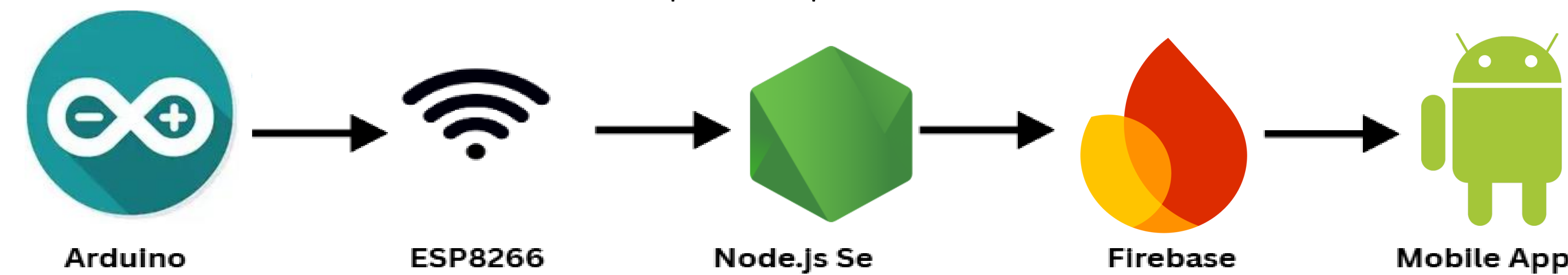

## BACKEND AND USER INTERFACE

### ESP8266 Wi-Fi module

- Uses POST requests to send sensor data to a backend for it to be logged
- Uses GET requests to receive on/off commands for each individual outlet from the user interface

### Node.js server (JavaScript)

- Creates web server using Express and enabling POST requests
- Sets up Firebase connection using a private key and the database URL
- When a POST request is sent from ESP8266 to the Node.js server, read data and save it to "sensors" in Firebase
- When a command changes in Firebase, the server will log it and return the command to the ESP8266 and Arduino when a GET request is sent

### Firebase

- A real time database where all the sensor data is sent and stored for the user interface to use for either displaying the data or calculations
- Relay switch state is also stored here and accessed by the ESP8266 with GET requests

### Android application (user interface)

- Where data from the voltage sensor will be displayed
- Able to send data through the entire system and back to the relays
- Feature for budget planning available

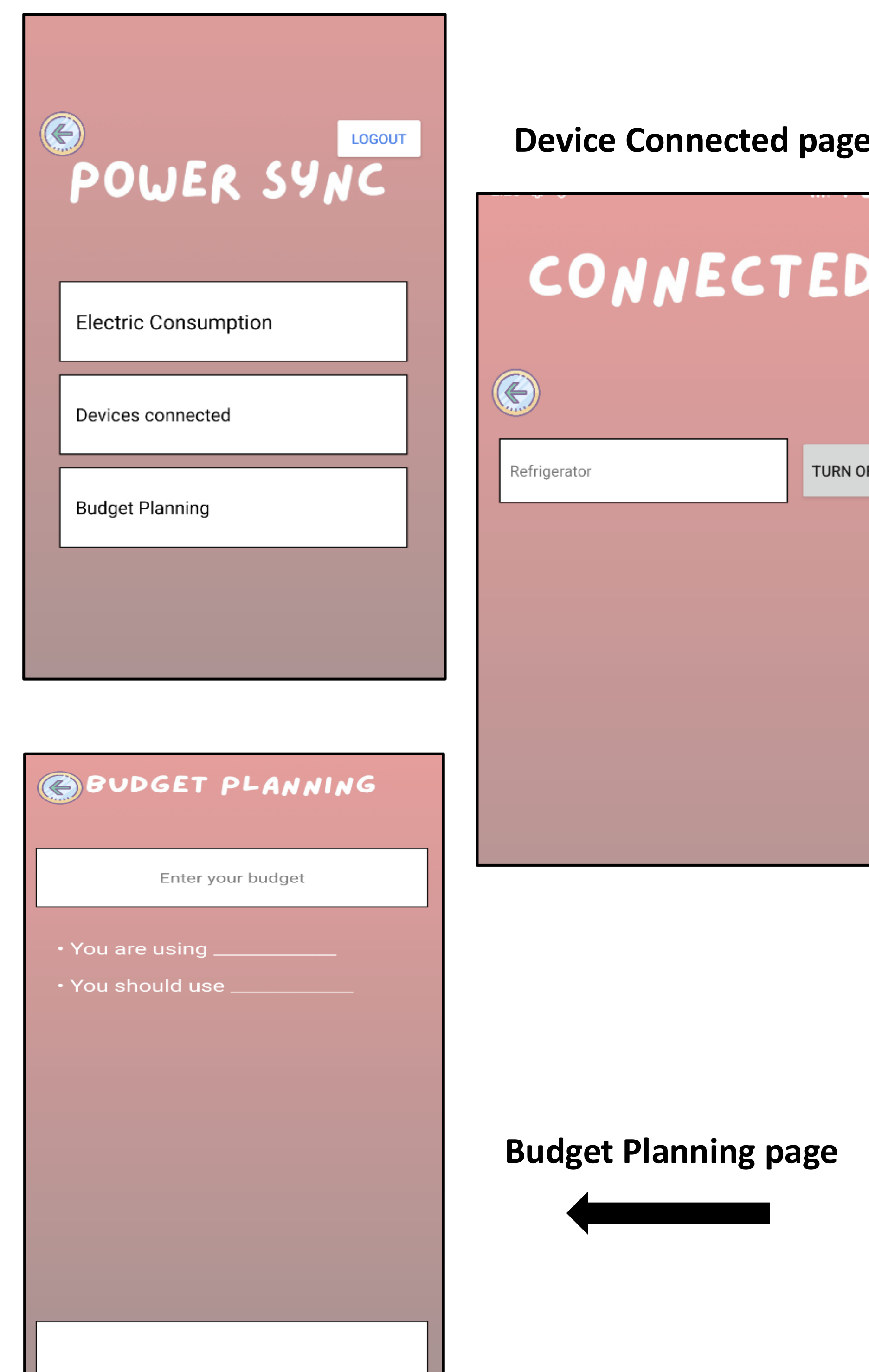

## HARDWARE

### Outlets

- Mains hot line to outlet hot line
- Mains neutral to outlet neutral
- Mains ground to outlet ground

### Voltage sensor modules

- Mains hot line to sensor L to outlet hot line
- Mains neutral to sensor N

### Relays

- Connects Mains voltage neutral to relays to outlet neutral

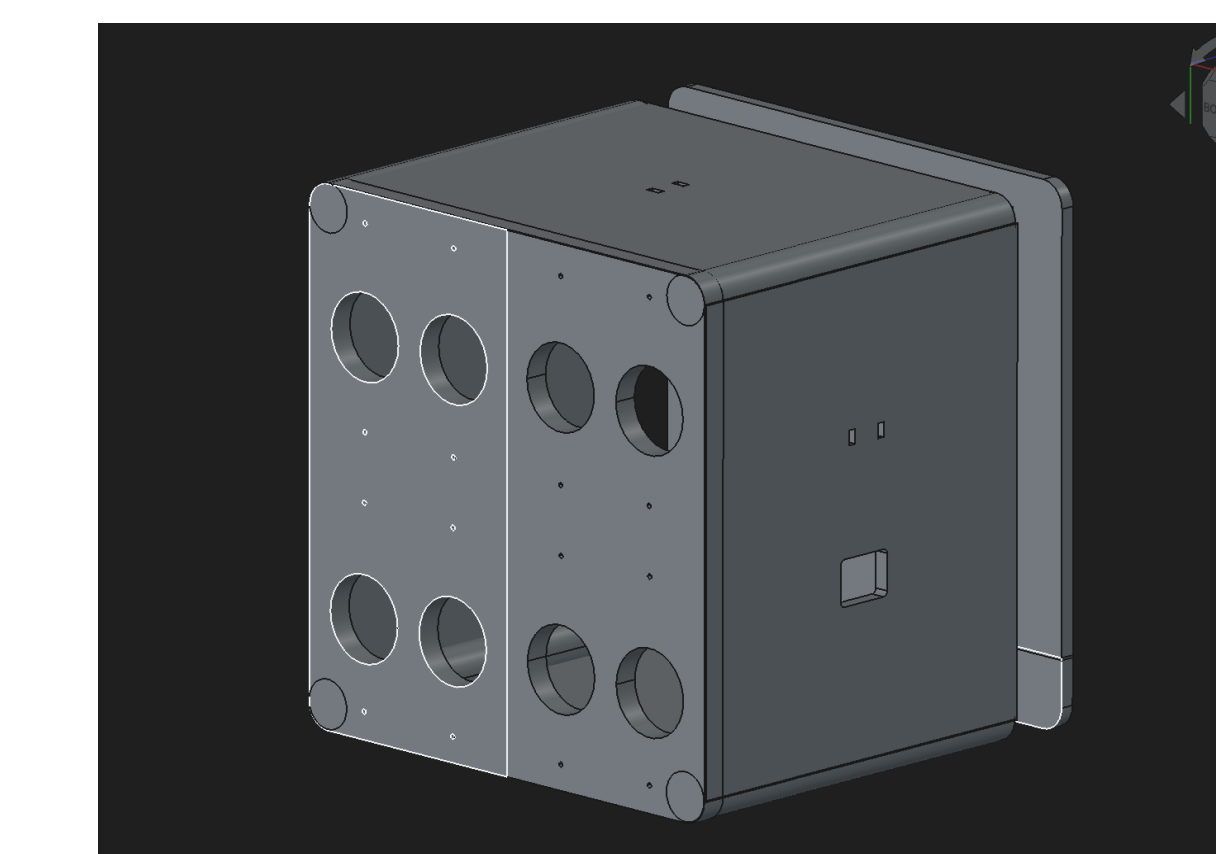

Link to GitHub repo



## CONCLUSION

### This project allowed us to

- Apply engineering and programming concepts to a real-world problem
- Gain experience in problem-solving, circuit design, 3D modeling, and user-focused development
- Further develop communication skills and self direction

### Some difficulties faced include

- 3D printed box not being the exact dimensions to fit all components in
- Time constraints, schedule conflicts, and trying to work on this project on top of school and other responsibilities
- Difficulties with setting up the Android app, needed to consult an upperclassmen in CS to help
- The mounting of the outlets aren't very stable on the 3D housing

## REFERENCE

- [1] "Arduino power strip: More enclosure & more wiring – Robert's Blog," *Dec2b.de*, 2020. <https://dec2b.de/posts/2020-11-17-arduino-power-strip-more-enclosure-and-more-wiring.html> (accessed Apr. 10, 2026).
- [2] "New Hampshire Electricity Rates & Average Electricity Bills," *Find Energy*. <https://findenergy.com/nh/>
- [3] Stefan, "Arduino WiFi with ESP8266 NodeMCU - Complete Setup Guide - Make It Hardware," *Make It Hardware*, Feb. 20, 2026. <https://makeithardware.com/arduino-wifi-with-esp8266-nodemcu-complete-setup-guide/> (accessed Apr. 17, 2026).
- [4] "Tutorials | Arduino Documentation," *docs.arduino.cc*. <https://docs.arduino.cc/tutorials/>