

Ningyu Liu(1), Stephen Horn(1), Frank D. Lind(2), Mark Stanley(3), and Joseph Dwyer(1)

(1) University of New Hampshire, NH (2) MIT Haystack Observatory, MA (3) New Mexico Tech, NM



## Abstract

The Radio Interferometer for Thunderstorm Studies (RIFTS) is a deployable, high-performance radio sensor array specifically designed to map and image lightning. Developed collaboratively by UNH and MIT Haystack Observatory, the 8-node array utilizes a mix of LWA, SKALA-2, and OmniLOG antennas to cover a broad frequency range from 10 MHz to 1.6 GHz. The array nodes are connected via RF coaxial cables to a central station, where signals are coherently digitized using the latest RF system-on-chip (RFSoc) technology.

At its core, the SDR architecture leverages the Xilinx RFSoc ZCU216 for direct RF digitization up to 2.5 GHz. To handle the extreme data throughput, we developed custom FPGA designs via the CASPER toolflow. RIFTS currently supports two adaptable modes: a triggered mode utilizing a coarse polyphase filter bank (PFB) to capture 0.5-second bursts across eight 500 MHz channels to onboard DDR4, and a continuous observation mode streaming four 31.25 MHz channels via 10 GbE. This poster presents the design, hardware integration, and software development of the RIFTS SDR architecture, alongside testing results from the operational array.

## Architectural Design

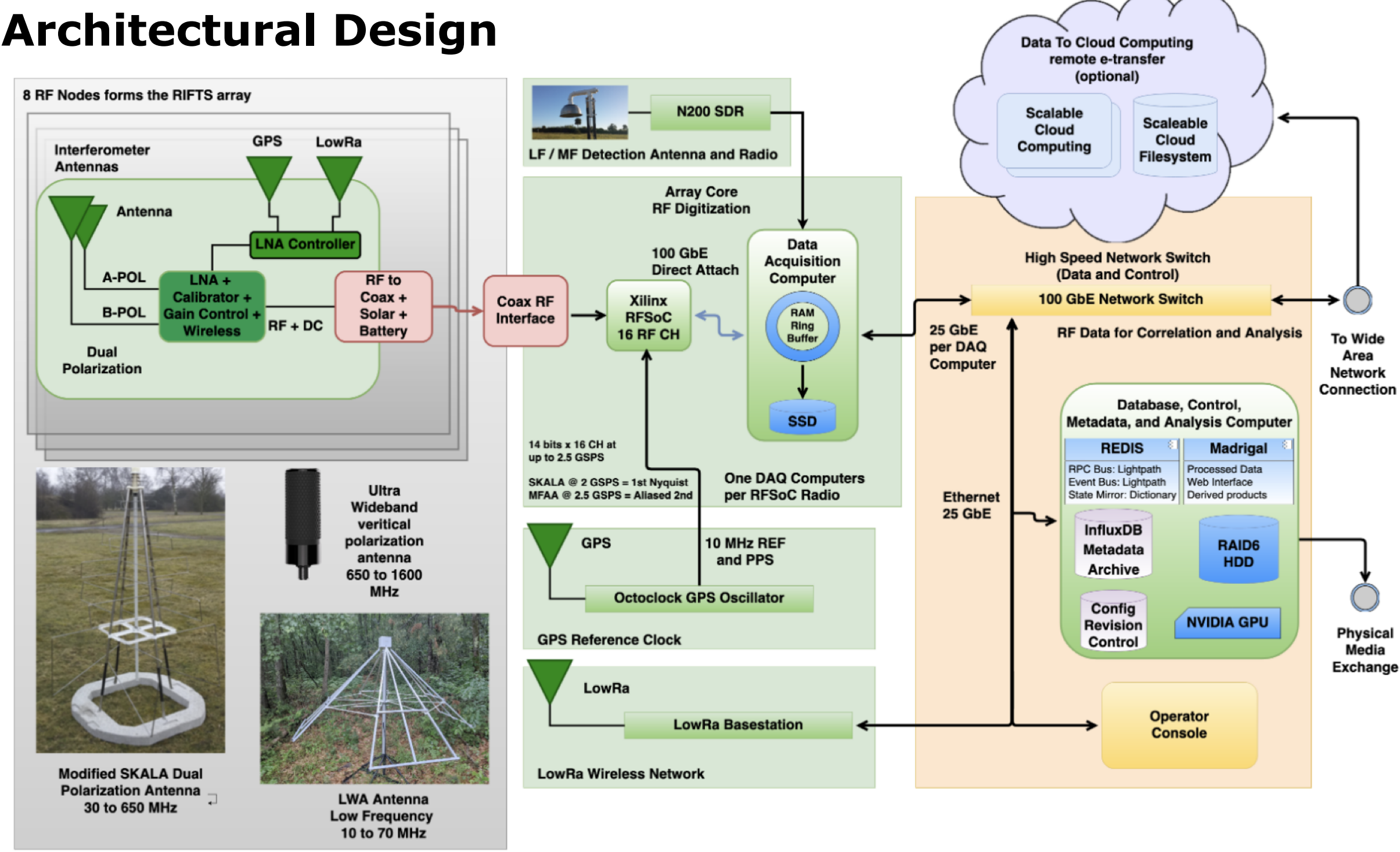

## UNH Observatory Field Site

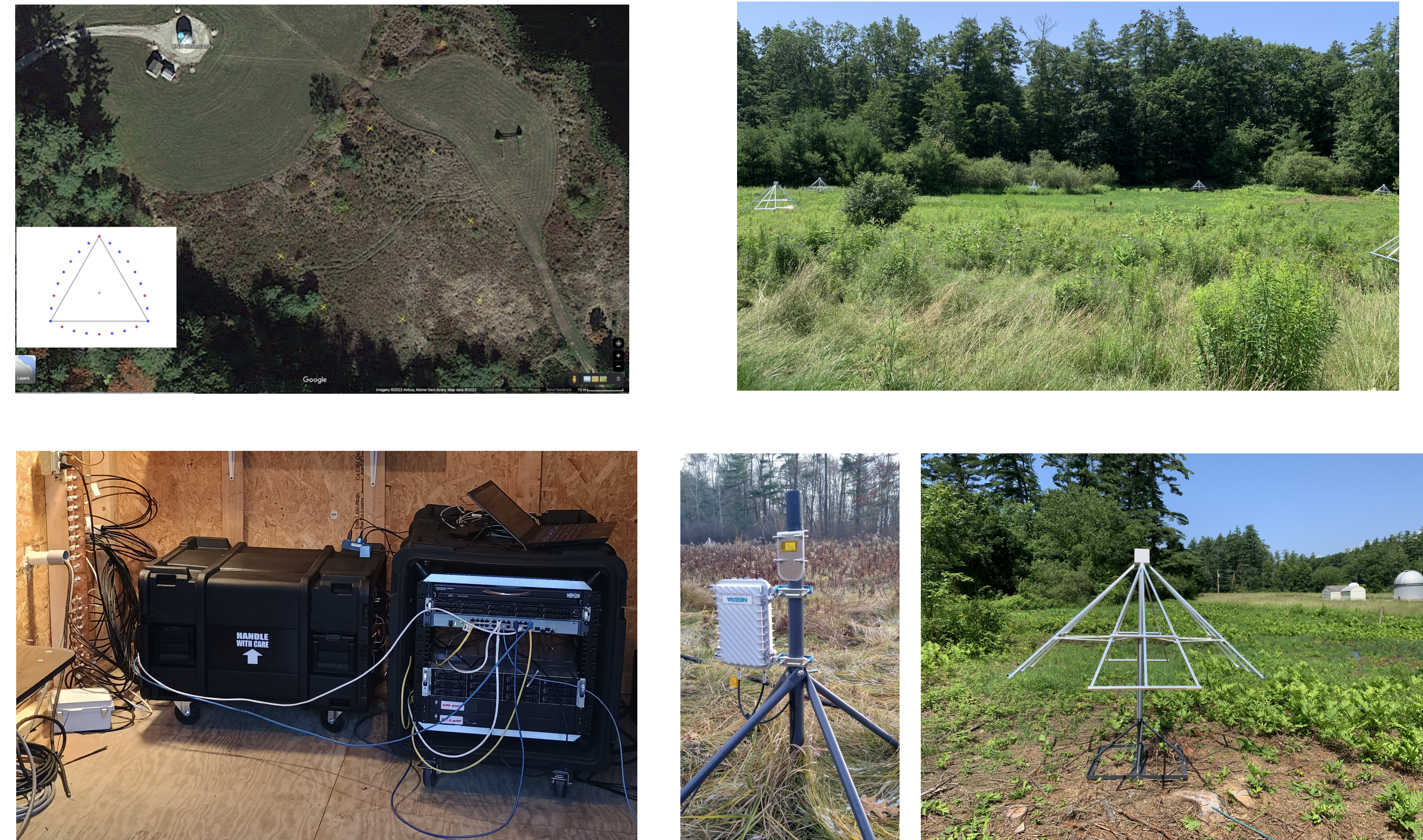

- Eight nodes on baselines up to 200 meters
- LWA, SKALA2 and OmniLOG antennas to cover a bandwidth of 10 to 1600 MHz
- Central data acquisition and processing core
- RFSoc digitization (direct sampling at  $\sim 1$  GHz)
- Dedicated lightning instrument (custom RF parts and RFSoc interface, configurable array layouts, in-house FPGA designs)

## RFSoc Processing Core and CASPER Toolflow-Based FPGA Design

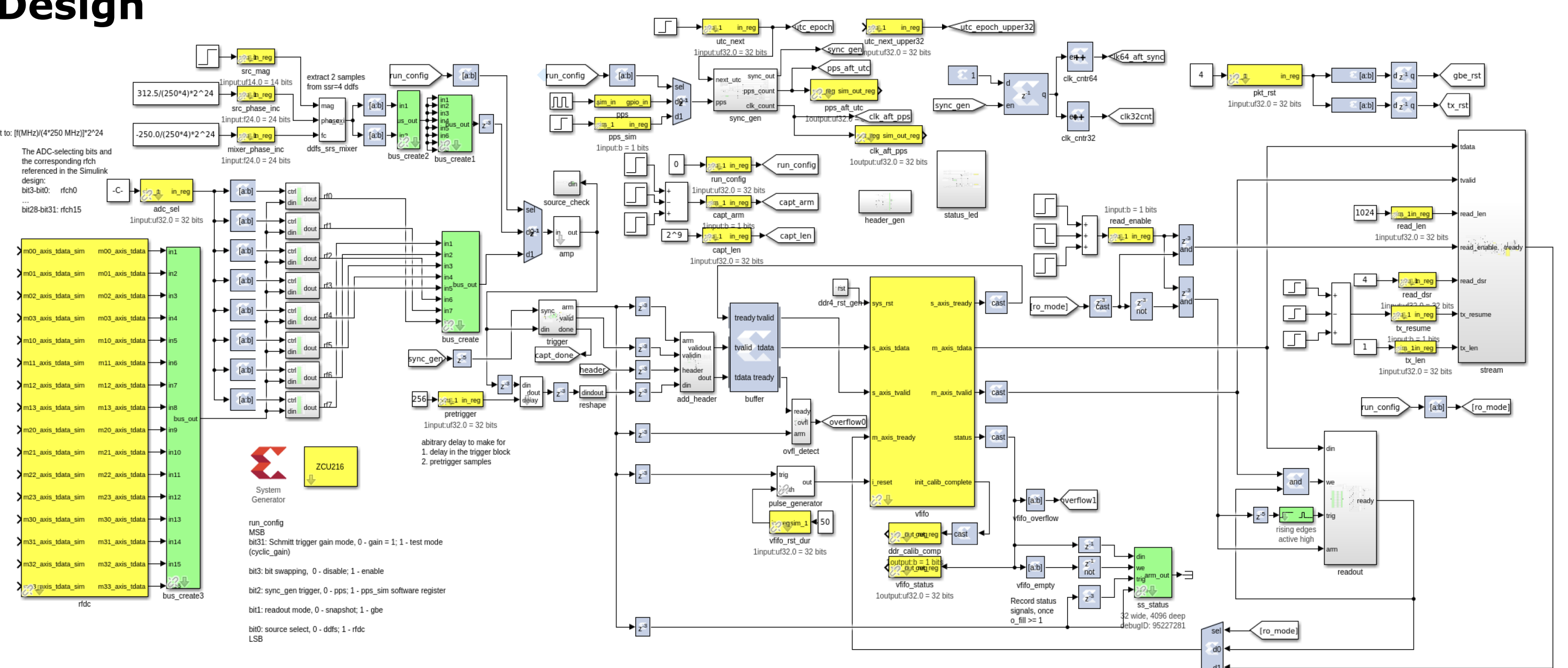
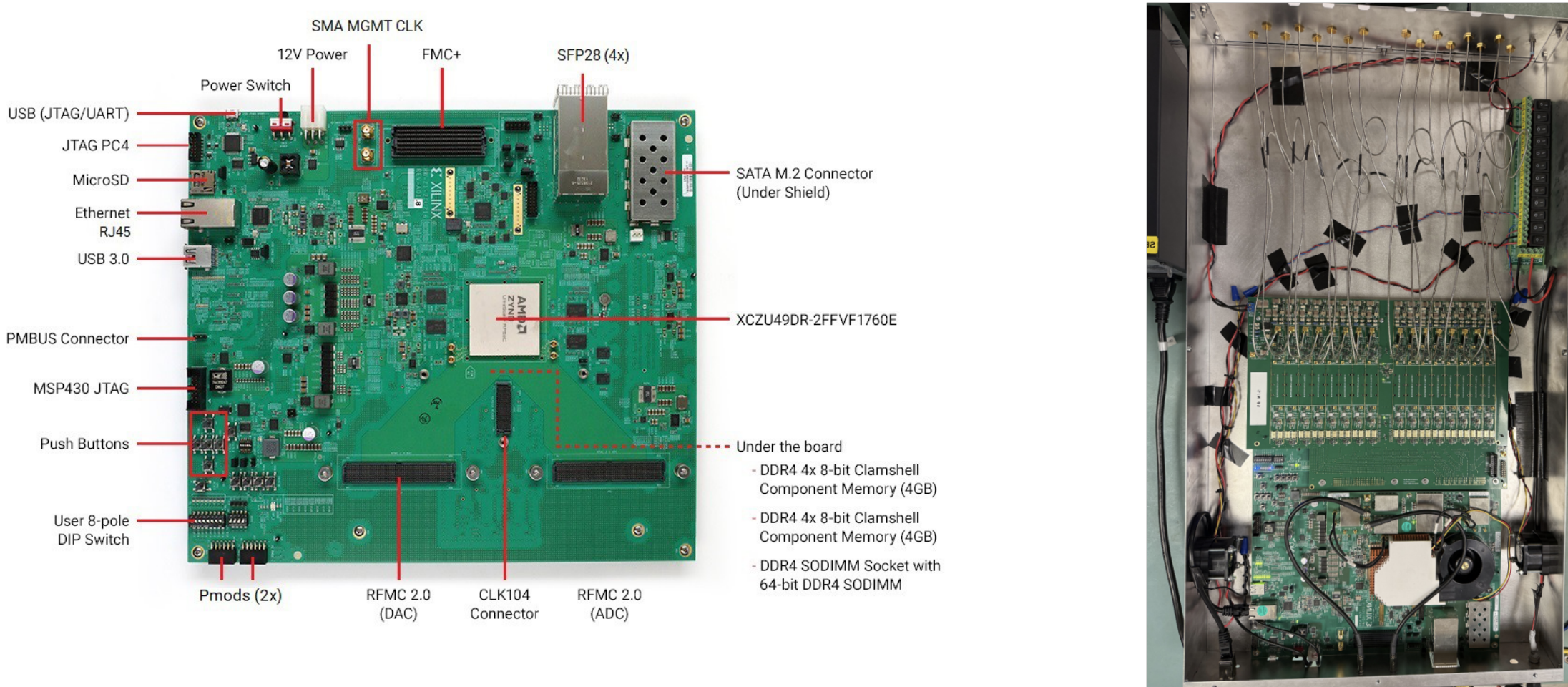

- AMD Xilinx ZCU216 RFSoc: 16 CH / 2.5 GSPS
- Custom RF Interface Board: Bias-T, Filtering, Gain, Calibration Input
- CASPER Toolflow-Based Design: Supports 8-channel burst captures at 1 GSPS per channel to onboard DDR4
- Frequency-Selective Trigger: Trigger frequency band selectable via a coarse polyphase filter bank
- Precision Synchronization: Phase-locks all system clocks to external 10 MHz and PPS

## Results I: Imaging Local Lightning

UTC: 21:00:43.336712766 U | Rel: +391.800 ms

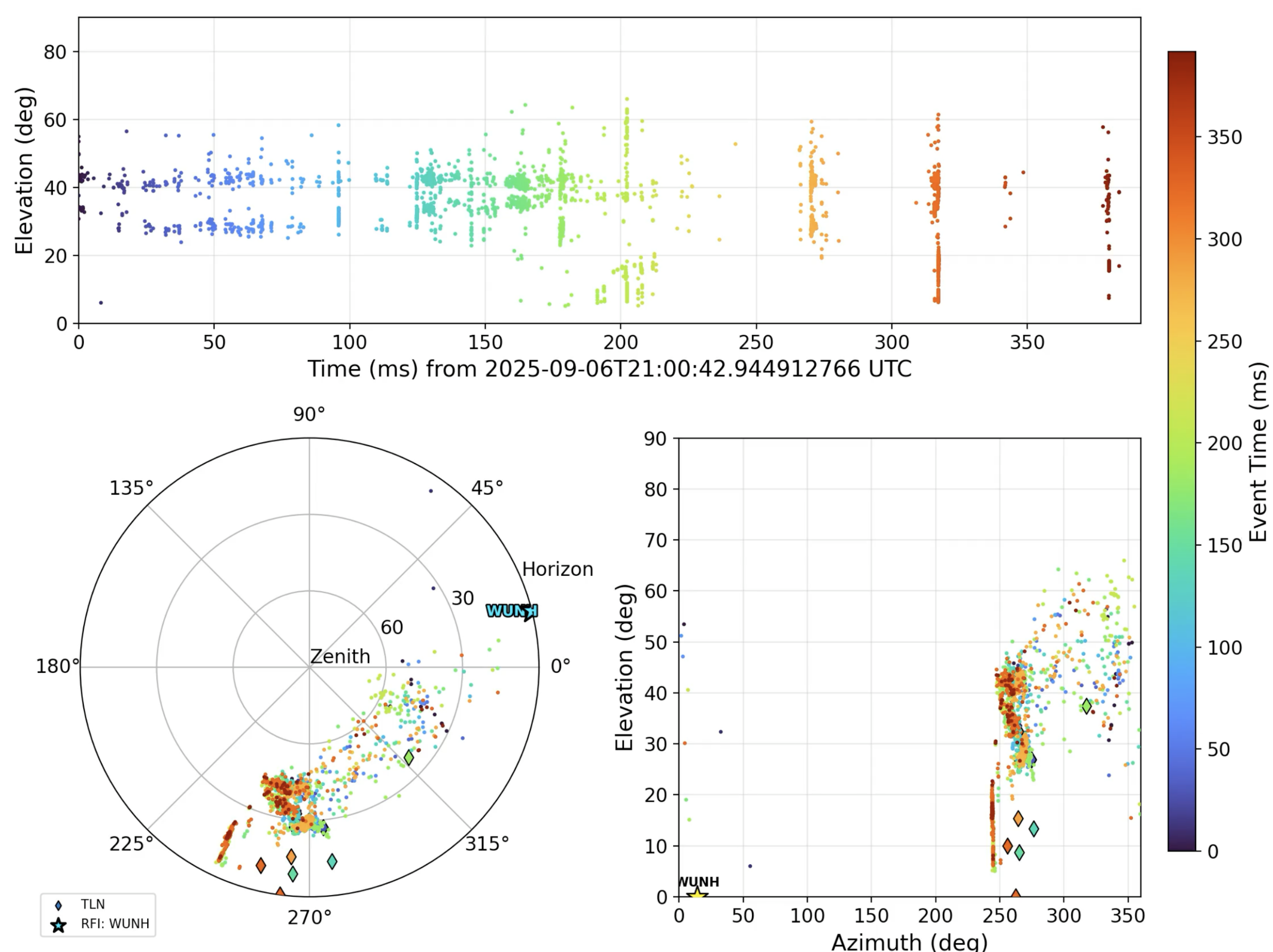

## Results II: Skywave Observation of Distant (> 1000 km) Lightning

Spectrogram: t=0 at 2026-05-07T09:24:54.876 UTC

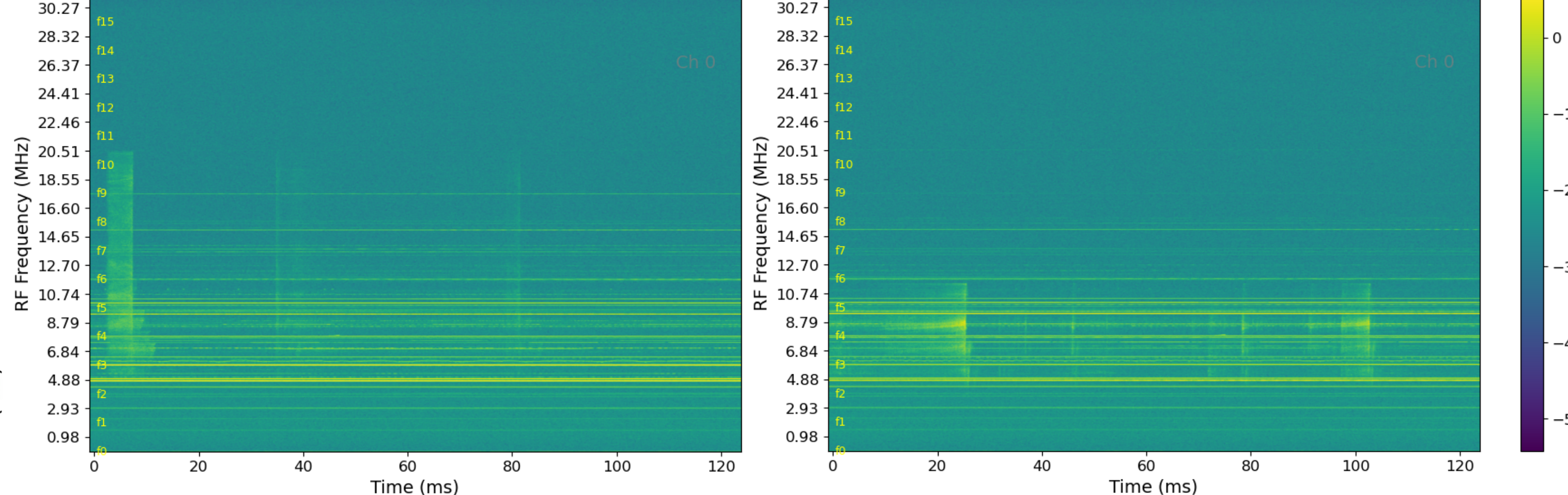

## References

- Liu, N. Y., F. D. Lind, I. Dors, A. Steckler, S. Horn, M. A. Stanley, J. R. Dwyer, D. Abel, A. Johnson, V. Yu, and H. E. Spence, RIFTS: A broadband VHF-UHF interferometer to study lightning, AGU Fall Meeting, December 11-15, 2023.
- Liu, N. Y., S. Horn, F. D. Lind, M. Stanley, and J. Dwyer, CASPER Toolflow based FPGA design for lightning radio interferometers, AGU Fall Meeting, December 9-13, 2024.

## Acknowledgments

This research has been supported by AFOSR Awards FA9550-21-1-0366 and FA9550-24-1-0124 to the University of New Hampshire and by the Space Science Center of the University of New Hampshire. We also thank the undergraduate students and engineers who contributed to this project.